

RESTRICTED

AN 01-40ALA-1

Pilot's Handbook

for

NAVY MODEL

AD-2

Airplane

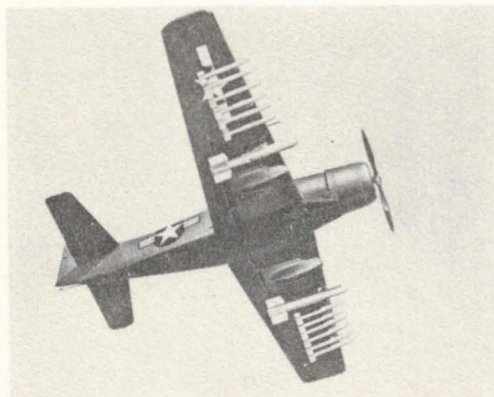

PUBLISHED UNDER AUTHORITY OF THE SECRETARY OF THE AIR FORCE
AND THE CHIEF OF THE BUREAU OF AERONAUTICS

NOTICE.—This document contains information affecting the national defense of the United States within the meaning of the Espionage Act, 50 U. S. C., 31 and 32, as amended. Its transmission or the revelation of its contents in any manner to an unauthorized person is prohibited by law.

15 May 1948

RESTRICTED
AN 01-40ALA-1

Reproduction of the information or illustrations contained in this publication is not permitted without specific approval of the issuing service. The policy for use of Classified Publications is established for the Air Force in AR 380-5 and for the Navy in Navy Regulations, Article 76.

LIST OF REVISED PAGES ISSUED

INSERT LATEST REVISED PAGES. DESTROY SUPERSEDED PAGES.

NOTE: The portion of the text affected by the current revision is indicated by a vertical line in the outer margins of the page.

* The asterisk indicates pages revised, added or deleted by the current revision.

BuAer

ADDITIONAL COPIES OF THIS PUBLICATION MAY BE OBTAINED AS FOLLOWS:

USAF ACTIVITIES.—In accordance with Technical Order No. 00-5-2.

NAVY ACTIVITIES.—Submit request to nearest supply point listed below, using form NavAer-140; NAS, Alameda, Calif.; ASD, Orote, Guam; NAS, Jacksonville, Fla.; NAS, Norfolk, Va.; NASD, Pearl City, Oahu; NASD, Philadelphia, Pa.; NAS, San Diego, Calif.; NAS, Seattle, Wash.

For listing of available material and details of distribution see Naval Aeronautics Publications Index NavAer 00-500.

RESTRICTED

SCANNED BY AVIALOGS.COM

TABLE OF CONTENTS

SECTION I		<i>Page</i>
DESCRIPTION	<i>Page</i>	
1-1 General	1	2-66 Night Flying 18
1-4 Flight Controls	4	2-68 Approach 18
1-11 Power Plant Controls	4	2-71 Landing 18
1-25 Fuel System Controls	5	2-81 Stopping the Engine 18
1-29 Oil System	5	2-83 Before Leaving the Airplane 19
1-31 Landing Gear Controls	5	
1-37 Wing Folding	7	SECTION III
1-39 Hydraulic System Controls	7	EMERGENCY OPERATING INSTRUCTIONS
1-42 Electrical System Controls	7	3-1 Fire 21
1-47 Miscellaneous	7	3-8 Engine Failure 22
1-52 Operational Equipment	7	3-11 Escape From Airplane 22
		3-13 Forced Landing 22
		3-17 Propeller Emergency Operation 22
		3-19 Fuel System Emergency Operation 23
		3-24 Systems and Controls Emergency Operation 23
		3-41 Miscellaneous Emergency Equipment 24
SECTION II		
NORMAL OPERATING INSTRUCTIONS		
2-1 Before Entering the Cockpit	9	
2-5 On Entering the Cockpit	10	
2-7 Fuel System Management	11	
2-12 Starting Engine	11	
2-13 Warm-Up	12	
2-14 Ground Test	12	
2-25 Taxiing	13	
2-27 Before Take-Off	13	
2-31 Take-Off	14	
2-36 Climb	14	
2-40 During Flight	14	
2-55 Stalls	16	
2-57 Spins	17	
2-59 Permissible Acrobatics	17	
2-61 Diving	17	
		SECTION IV
		OPERATIONAL EQUIPMENT
		4-1 Armament Equipment 25
		4-42 Oxygen Equipment 27
		4-49 Radio, Communication, Navigation and Special Electronic Equipment 29
		4-100 Windshield Defogger and Foot Warmer System 33
		4-102 Ventilation System 33
		4-104 Windshield Degreasing System 33
		4-106 Lighting Equipment 33
		APPENDIX I
		A-1 Flight Planning 35

LIST OF ILLUSTRATIONS**SECTION I
DESCRIPTION**

<i>Figure</i>		<i>Page</i>
1-1	Model AD-2 Airplane	iii
1-2	General Arrangement Diagram	1
1-3	Pilot's Cockpit	2
1-4	Surface Controls Lock	4
1-5	Fuel System Diagram	6
1-6	Miscellaneous Equipment Diagram	8

**SECTION II
NORMAL OPERATING INSTRUCTIONS**

2-1	Entrance to Airplane	10
2-2	Operating Flight Strength Diagram	16
2-3	Mooring	19

**SECTION III
EMERGENCY OPERATING INSTRUCTIONS**

3-1	Emergency Equipment and Exits	21
-----	---	----

**SECTION IV
OPERATIONAL EQUIPMENT**

4-1	Armament Control Panel	25
4-2	Bomb Ejector Test Box	26
4-3	Heat and Vent System Diagram	32

**APPENDIX I
OPERATING CHARTS**

A-1	Protection from Gunfire Diagram	36
A-2	Airspeed Installation Correction Table	37
A-3	Stalling Speed vs. Gross Weight Relationships	37
A-4	Power Plant Charts	38
A-5	Engine Calibration Curve	40
A-6	Angle of Attack Relationships	41
A-7	Take-Off, Climb and Landing Chart	43
A-8	Flight Operating Instruction Charts	44

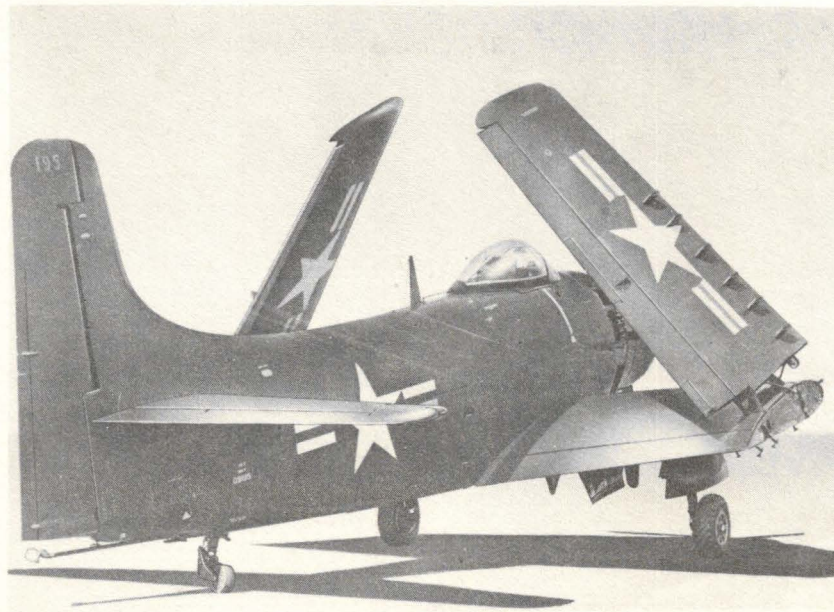
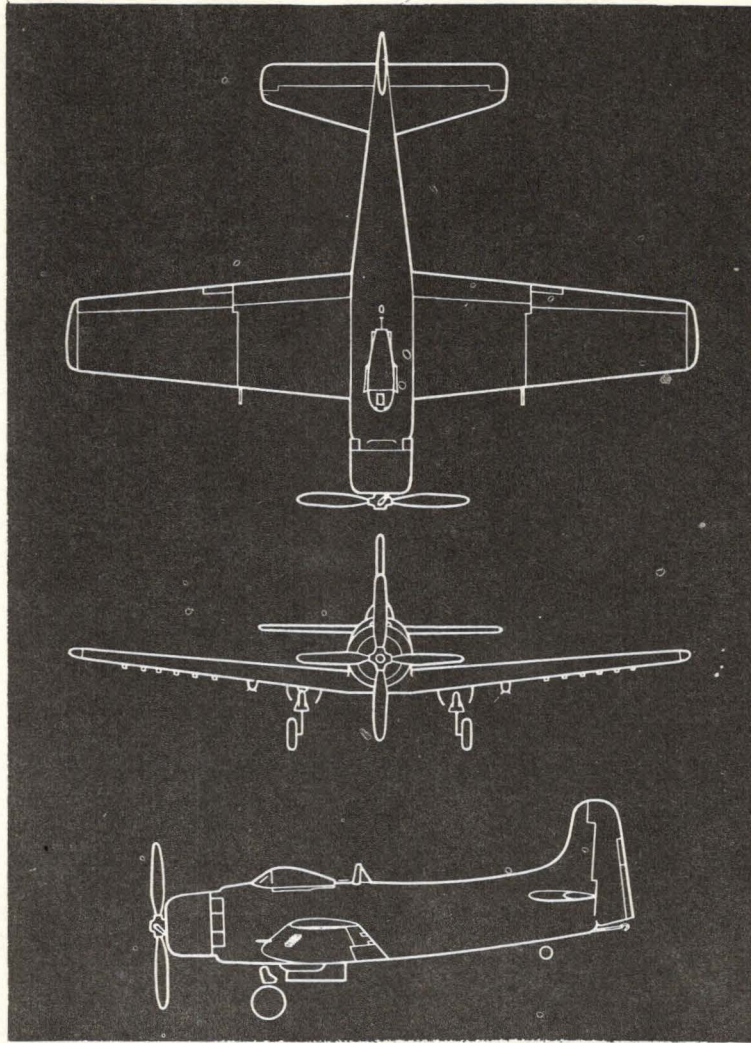
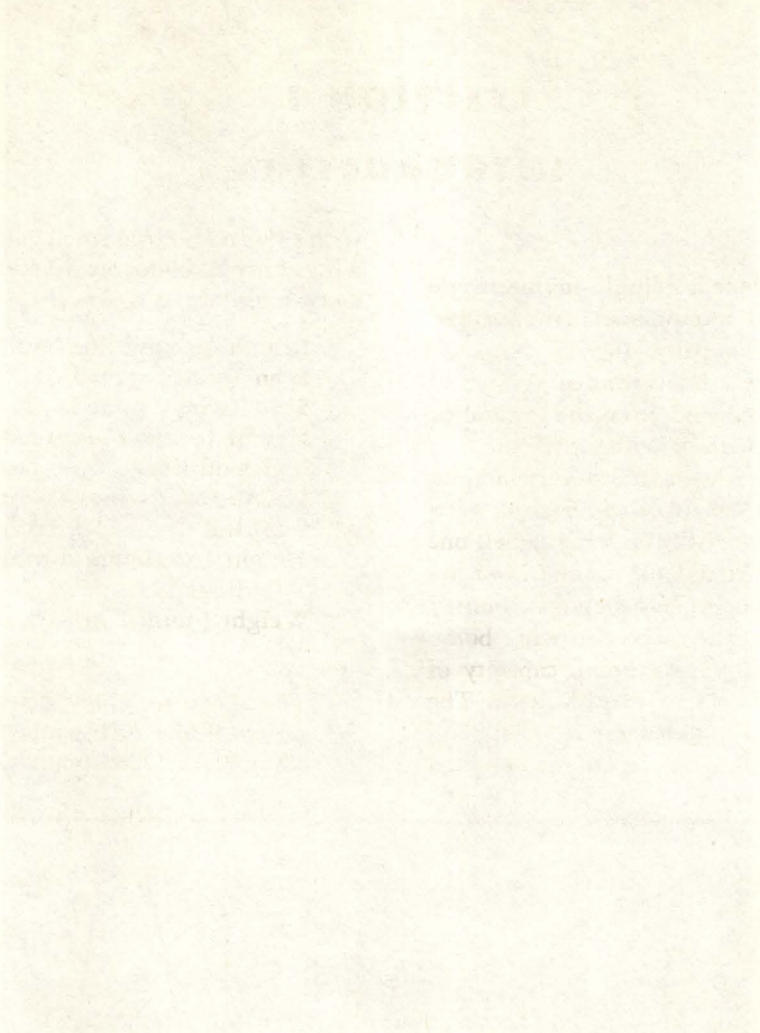

Figure 1-1. Model AD-2 Airplane



SECTION I

INTRODUCTION

1-1. GENERAL.

1-2. The Model AD-2 airplane is a single-engine, single place, low wing all metal monoplane manufactured by the Douglas Aircraft Company, Inc.; El Segundo Plant. It is equipped with a conventional tail-wheel type landing gear and can take-off from the ground or from the deck of a carrier, with or without the aid of a catapult. Landings can be made on an ordinary landing field, or a carrier deck with the aid of an arresting gear. Two 20 mm guns are mounted in the wing panel, one at each folding joint. 200 rounds of ammunition are provided for each gun. Six rocket launchers are mounted under each outboard wing panel. The two wing bomb racks are capable of carrying a maximum capacity of a 2000-pound bomb or a MK 13-3 torpedo each. The fuselage bomb ejector rack can also carry a 2000-pound bomb or a MK 13-3 torpedo. The airplane is designed

with side and bottom fuselage dive brakes. The folding wings have a six-degree dihedral. Principal dimensions and weight are as follows:

Length (ground line level).....	39 ft. 3 13/32 in.
Span (wings spread).....	50 ft. 0 in.
Span (wings folded).....	24 ft. 0 in.
Height (overtail-measured from ground line)	12 ft. 0 in.
Height (over wings—wings folded)	16 ft. 8 in.
Height (maximum during folding)	19 ft. 5 3/32 in..
Weight (normal gross).....	16,277 lbs.

Note

The above weight is determined with a condition of one 2000-pound bomb installed and 380 gallons (2280 pounds) of fuel.

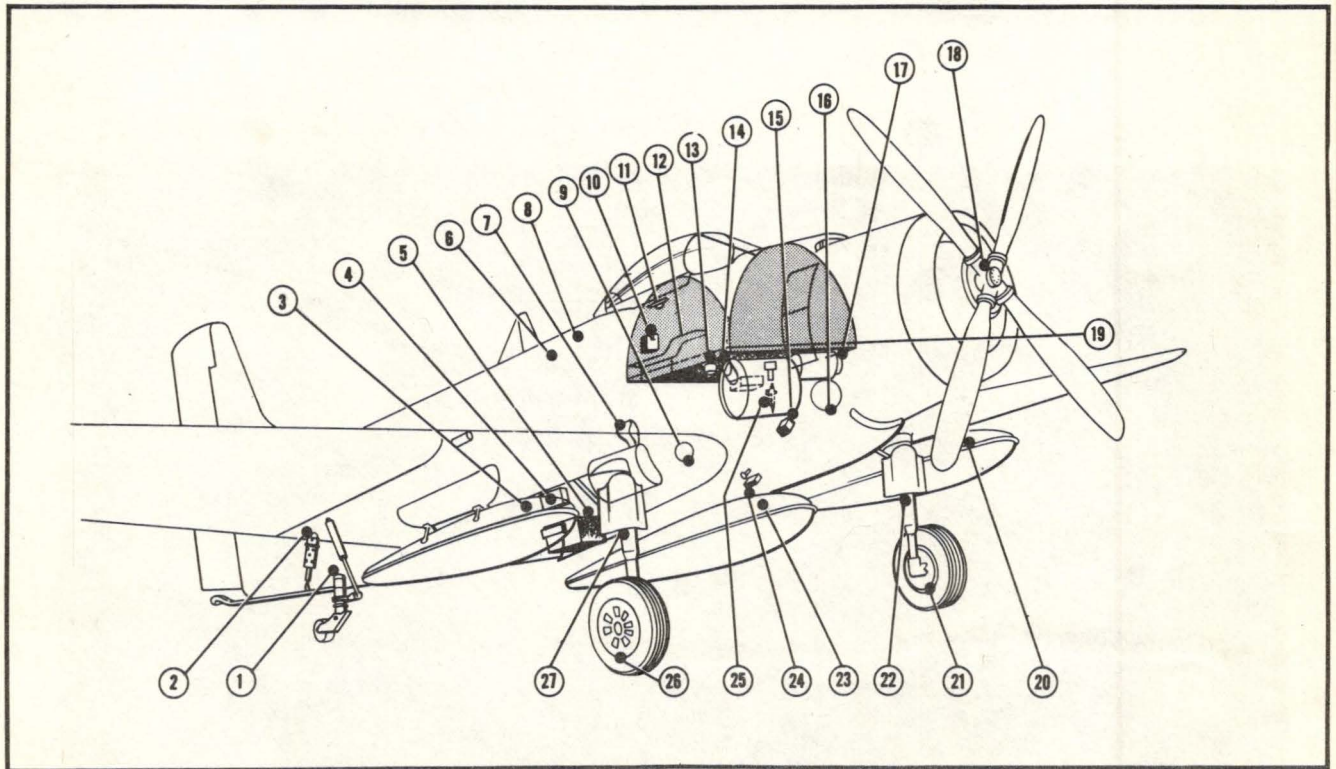

- | | | |
|--|--|---|
| 1. Tail Gear Shock Strut | 10. Canteen | 19. Pilot's Floor (Reference) |
| 2. Arresting Gear Holddown Unit | 11. Oxygen Tank Filler Valve | 20. Left Wing Auxiliary Fuel Tank |
| 3. Right Wing External Auxiliary Fuel Tank | 12. Electrical Circuit Breaker Panel | 21. Left Wheel Tire Air Pressure Valve |
| 4. Power Junction Box | 13. Windshield Degreasing Tank | 22. Left Wheel Shock Strut |
| 5. Battery | 14. Oil Tank Filler Well | 23. Fuselage External Auxiliary Fuel Tank |
| 6. Main Fuel Tank Grounding Receptacle | 15. Power Plant Electrical Junction Box | 24. External AC and DC Power Receptacle |
| 7. Water Injection System Tank | 16. Hydraulic Accumulator | 25. Landing Gear Emergency Control Valve |
| 8. Main Fuel Tank Filler Well | 17. Hydraulic Reservoir | 26. Right Wheel Tire Air Pressure Valve |
| 9. Hydraulic Enclosure Accumulator | 18. Propeller Hydraulic Fluid Filler Opening | 27. Right Wheel Shock Strut |

Figure 1-2. General Arrangement Diagram

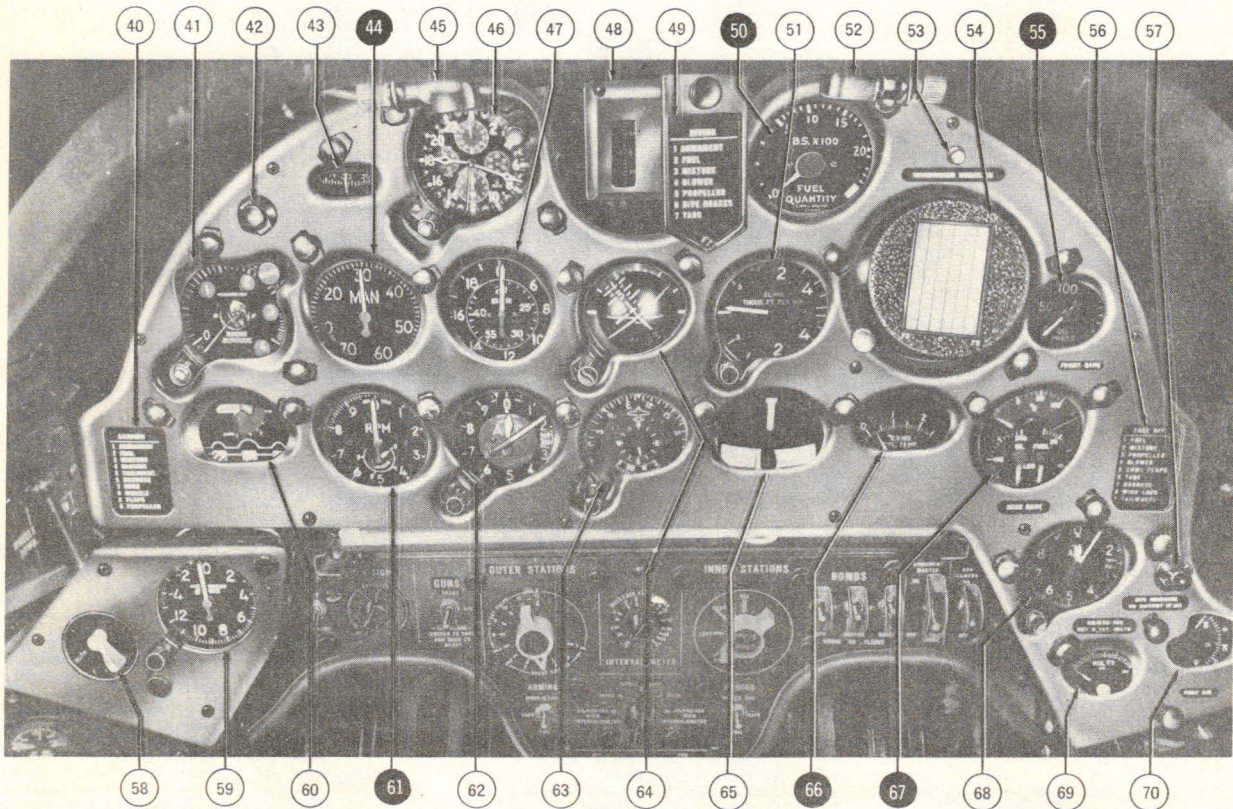
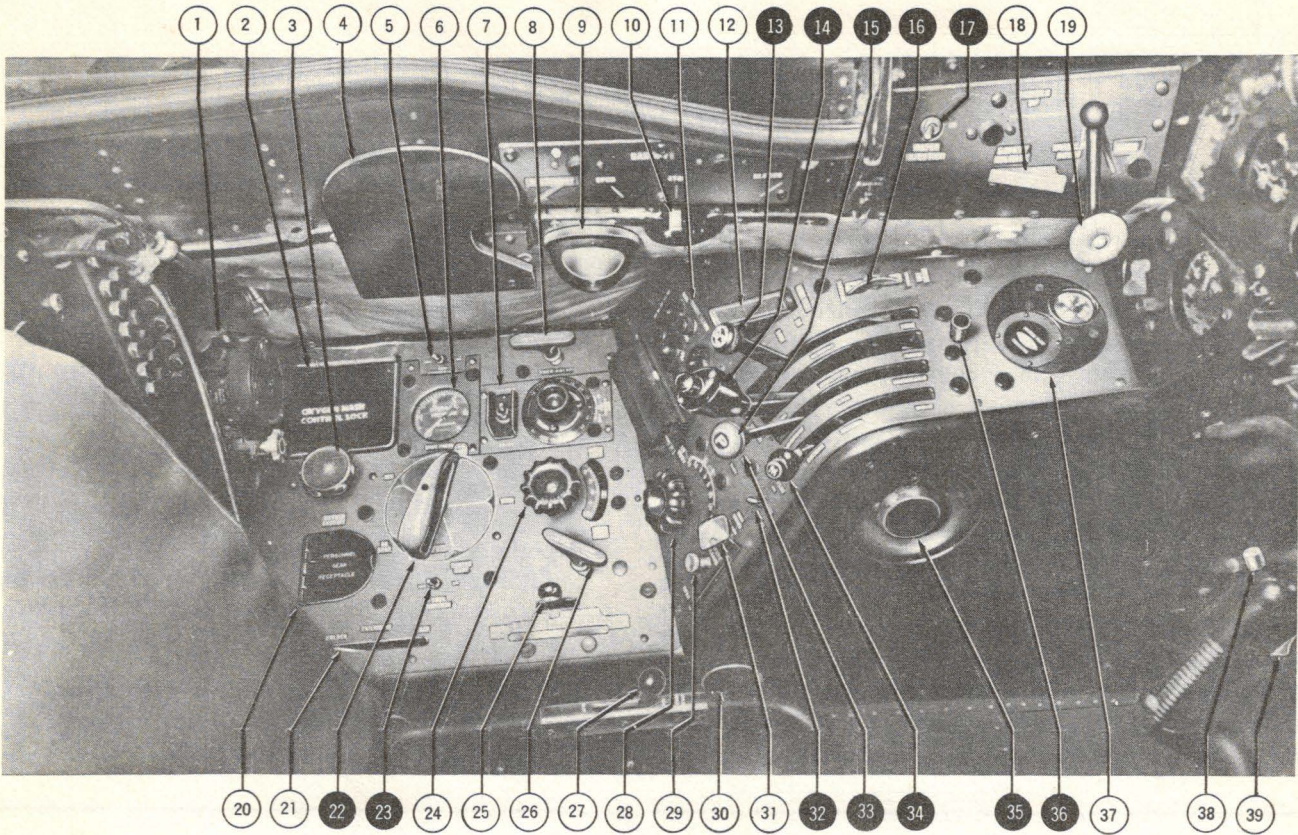
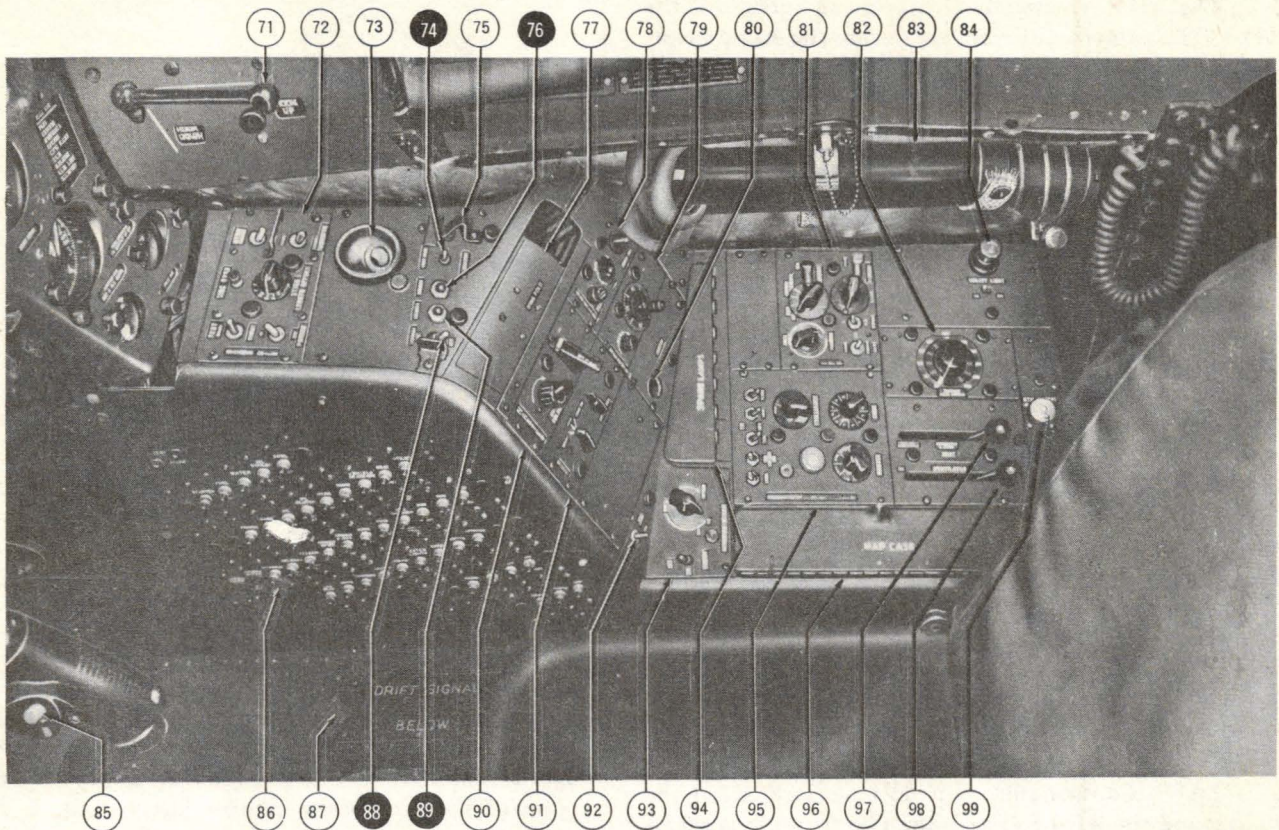

Figure 1-3 (Sheet 1 of 2 Sheets). Pilot's Cockpit



- | | | |
|---|--|--|
| 1. Oxygen Regulator and Emergency Control Valve | 35. Throttle and Propeller Pitch Friction Lock | 70. Outside Air Temperature Indicator |
| 2. Oxygen Mask and Control Lock Stowage | 36. Static Throttle Grip | 71. Arresting Hook Control |
| 3. Oxygen Shut-off Valve | 37. Oxygen Flow Indicator and Pressure Gage | 72. AN/ASG-10A Electronic Bombing Panel |
| 4. Armrest | 38. Bomb Release Button | 73. Ventilating Air Outlet (Eyeball) |
| 5. Emergency Hydraulic Pump Switch | 39. Gun Trigger Switch | 74. Pitot Heater and Oil Dilution Switch |
| 6. Hydraulic System Pressure Gage | 40. Landing Check-Off List | 75. Approach Light Manual Switch and Guard |
| 7. Gunsight Elevation Console Panel | 41. Radio Altimeter | 76. Engine Primer Switch |
| 8. Emergency Bomb Release Control | 42. Radio Altimeter Warning Light | 77. Wing Fold Control |
| 9. Ash Tray | 43. Standby Compass | 78. AN/ARR-2A Navigation Radio Console Panel |
| 10. Cockpit Enclosure Control | 44. Manifold Pressure Gage | 79. AN/ARC-5 Radio Range Receiver Console Panel |
| 11. AN/APS-4 Radar Console Panel | 45. Instrument Panel Light | 80. Cigarette Lighter |
| 12. Wing Flap Control | 46. Clock | 81. AN/APX-2 Identification Radio Console Panel |
| 13. Supercharger Control | 47. Airspeed Indicator | 82. AN/APN-1 Radio Altimeter Console Panel |
| 14. Throttle Control and Microphone Switch | 48. Gunsight | 83. Radar Scope |
| 15. Propeller Pitch Control | 49. Diving Check-off List | 84. Utility Light |
| 16. Carburetor Air Switch Control | 50. Fuel Quantity Indicator | 85. Rocket Release Switch |
| 17. Water Injection Master Switch (Inoperative) | 51. Rate of Climb Indicator | 86. Circuit Breaker Panel |
| 18. Landing Gear Safety Release | 52. Instrument Panel Light | 87. Drift Signal Container |
| 19. Landing Gear Control | 53. Windshield Degrease Control | 88. Battery Switch |
| 20. Personnel Gear Receptacle | 54. Radar Scope | 89. Starter Switch |
| 21. Tail Wheel Lock Control | 55. Front Bank Oil Pressure Gage | 90. Master Radio Switch and Volume Control Console Panel |
| 22. Fuel Tank Selector Valve | 56. Take-Off Check-Off List | 91. AN/ARC-1 (VHF) Radio Console Panel |
| 23. Fuel Booster Pump Switch | 57. Generator Warning Light | 92. Seat Adjustment Switch |
| 24. Rudder Trim Tab Control | 58. Ignition Switch | 93. Interior Lights Console Panel |
| 25. Horizontal Stabilizer Control | 59. Accelerometer | 94. Spare Lights Container |
| 26. Aileron Boost Emergency Release | 60. Flap and Gear Position Indicator | 95. Exterior Lights Console Panel |
| 27. Shoulder Harness Control | 61. Tachometer | 96. Map Case |
| 28. Aileron Trim Tab Control | 62. Altimeter | 97. Heating Distributor Valve Control |
| 29. Dive Brake Safety Solenoid Control | 63. Master Direction Indicator | 98. Ventilator Control |
| 30. Relief Valve | 64. Attitude Gyro | 99. Utility Outlet |
| 31. Dive Brake Control | 65. Turn and Bank Indicator | |
| 32. Cowl Flap Control Switch | 66. Cylinder Head Temperature Indicator | |
| 33. Oil Cooler Door Switch (Hidden) | 67. Engine Gage Unit | |
| 34. Mixture Control Lever | 68. AN/ASG-10A Altimeter | |
| | 69. Voltmeter | |

Figure 1-3 (Sheet 2 of 2 Sheets). Pilot's Cockpit

1-3. The AD-2 is basically an improved version of the AD-1. The primary differences are that the AD-2 incorporates an R-3350-26W engine, an increased capacity fuel tank, landing gear doors, and a completely modernized cockpit section, including indirect plastic lighting and console-type panels.

1-4. FLIGHT CONTROLS.

1-5. SURFACE CONTROLS. Conventional control stick and rudder pedals are provided. An hydraulically operated aileron power boost system is provided. An emergency release handle (figure 1-3, reference 26) will disconnect the system in case of hydraulic failure. Position of both rudder pedals may be adjusted simultaneously by means of a crank (figure 4-1, reference 6) located just below the armament panel.

1-6. SURFACE CONTROL LOCK. The surface controls lock assembly (figure 1-4) consist of a cap, two short (forward) cables and two long (after) cables equipped with attaching hooks. When the cap is set over the stick grip and one of the forward cables is hooked to each rudder pedal and the aft cables are hooked on the sides of the cockpit, the controls are locked in neutral. The lock assembly may be stowed in a compartment located in the cockpit marked "CONTROL LOCK." (See figure 1-3, reference 2.)

1-7. TABS. Controllable trim tabs are located on the rudder and the left-hand aileron. The trim tab controls (figure 1-3, references 24 and 28) are located on the left-hand console panel. A fixed trim tab, adjustable on the ground only, is provided on the right-hand aileron. Spring tabs, which are linked directly to the surface to reduce forces, are provided on the rudder and on the ailerons of airplanes not incorporating the aileron power boost system. (See paragraph 1-5.)

1-8. HORIZONTAL STABILIZER. Longitudinal trim is accomplished by an adjustable horizontal stabilizer in lieu of elevator tabs. The stabilizer is electrically operated and is controlled by a switch (figure 1-3, reference 25) on the left-hand console panel. A manual control is not provided. A position indicator, showing the recommended setting of the stabilizer for various flight conditions is provided adjacent to the control switch. When the indicated airspeed exceeds 190 knots (220 mph, the control will not permit stabilizer adjustment in the nose up range. This is accomplished through a pressure-actuated limit switch.

1-9. WING FLAPS. The wing flaps are hydraulically operated and are controlled by a lever (figure 1-3, reference 12) located on the left-hand console panel, just outboard of the engine controls. A wing flap position indicator (figure 1-3, reference 60) is provided on the instrument panel. The flaps are designed to blow back at speeds in excess of approximately 109 knots (125 mph) as a safety feature. It is recommended, however, that the flaps not be lowered at speeds in excess of 130 knots (150 mph).

1-10. DIVE BRAKES. Hydraulically operated fuselage side and bottom dive brakes are provided. The dive

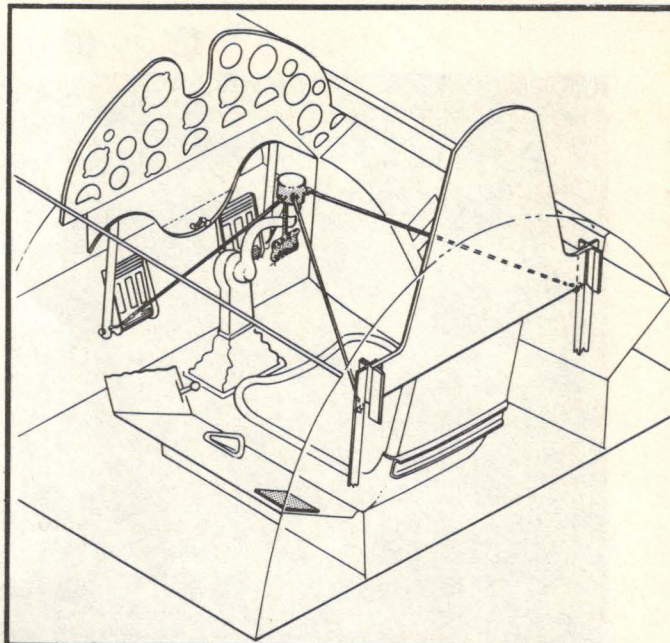

Figure 1-4. Surface Controls Lock

brakes are operated by a control (figure 1-3, reference 31) on the left-hand console panel. A solenoid safety lock actuated by the landing gear strut prevents movement of the dive brake control lever to the "OPEN" position when the airplane is on the ground (shock struts compressed). If the safety lock fails to operate properly in flight, the control lever may be moved to "OPEN" by depressing the solenoid release lever, located adjacent to the dive brake control.

1-11. POWER PLANT CONTROLS.

1-12. THROTTLE. The throttle is located in the left-hand console panel (figure 1-3, reference 14). A microphone switch is provided in the throttle grip. A static throttle grip for catapult take-off is installed just forward of the throttle and may be pushed down into the console panel when not in use.

Note

The engine is equipped with an automatic manifold pressure regulator.

1-13. SUPERCHARGER. The supercharger control (figure 1-3, reference 13) is located in the left-hand console panel, just outboard of the throttle.

1-14. MIXTURE CONTROL. The mixture control (figure 1-3, reference 34) is located in the left-hand console panel.

1-15. PROPELLER. A four-bladed Aeroproducts constant-speed, hydraulically actuated pitch type propeller, 13 feet 6 inches in diameter is provided. The propeller pitch control (figure 1-3, reference 15) is located in the left-hand console panel.

1-16. FRICTION ADJUSTMENT. A friction adjustment knob (figure 1-3, reference 35) is provided on the inboard side of the left-hand console unit and adjusts the friction on the throttle and propeller pitch levers.

1-17. **WATER INJECTION.** The master switch (figure 1-3, reference 17) is located on the left-hand side of the cockpit adjacent to the power plant control. The limit switch which places the system in operation is controlled by moving the throttle forward past the stop. (See paragraph 2-54.)

1-18. **CARBURETOR AIR.** The carburetor air door is electrically operated and is controlled by a switch (figure 1-3, reference 16) on the top of the left-hand console panel.

1-19. **COWL FLAPS.** The cowl flaps are electrically operated and may be set for either automatic or manual operation by a switch (figure 1-3, reference 32) on the left-hand console panel just below the power plant controls.

1-20. **OIL COOLER DOOR.** The oil cooler door is electrically operated and may be set for either automatic or manual operation by a switch (figure 1-3, reference 33) on the left-hand console panel inboard of the cowl flaps switch.

1-21. **OIL DILUTION.** The oil dilution-pitot heat control switch (figure 1-3, reference 74) is located on top of the right-hand console panel.

1-22. **PRIMER.** The primer button (figure 1-3, reference 76) is located on top of the right-hand console panel.

1-23. **STARTER.** The starter is of the direct cranking electric type and is controlled by a button (figure 1-3, reference 89) on the right-hand console panel, just inboard of the primer switch.

1-24. **IGNITION.** The ignition switch (figure 1-3, reference 58) is located just below the left-hand corner of the instrument panel.

1-25. FUEL SYSTEM CONTROLS.

1-26. **TANK SELECTOR.** A 380 U.S. gallon (2280-pound capacity) self-sealing fuel cell is provided in the fuselage just behind the cockpit. A 150 U.S. gallon (900-pound) capacity external auxiliary tank may also be carried on each bomb rack. Fuel is selected by the tank selector control (figure 1-3, reference 22) on the left-hand console panel.

1-27. **BOOSTER PUMP.** An electrically driven fuel booster pump is provided and is controlled by a switch (figure 1-3, reference 23) on the left-hand console panel, just inboard of the tank selector control.

1-28. **QUANTITY INDICATOR.** A "capacitance" type fuel quantity indicating system is provided. The gage (figure 1-3, reference 50) is located on the right-hand side of the instrument panel and indicates the fuel quantity of the main tank only in pounds. A fuel quantity indicating system is not provided for the external auxiliary tanks.

1-29. OIL SYSTEM.

1-30. **GENERAL.** The oil tank is located forward of the firewall and has a capacity of 32 U.S. gallons. The oil system operation is automatic; oil cooler door and oil dilution controls are provided. (See paragraphs 1-20 and 1-21.) The oil temperature and rear bank oil pressure are indicated on the engine gage unit (figure 1-3, reference 67). A separate gage (figure 1-3, reference 55) is provided for front bank oil pressure.

1-31. LANDING GEAR CONTROLS.

1-32. **NORMAL CONTROLS.** The landing gear control lever (figure 1-3, reference 19) is located on the left-hand side of the cockpit. With the hydraulic system operating the gear may be raised or lowered by moving the control to "WHEELS UP" or "WHEELS DOWN." Hydraulically actuated doors which operate in conjunction with the gear are also provided. A solenoid safety lock is provided to prevent inadvertent retraction of the gear when the airplane is on the ground. If the control lever cannot be moved to "WHEELS UP" in flight, the safety lock may be released by pushing the button adjacent to the lever.

1-33. **EMERGENCY CONTROLS.** If the landing gear fails to extend due to failure of the normal hydraulic system the landing gear control should be moved to the "EMER" position. If the emergency hydraulic pump has not already been turned on, moving the landing gear control will automatically turn on the emergency pump and furnish fluid from a reserve supply in the reservoir, available for lowering the main gear only, to the emergency pump to lower the gear. After using the landing gear in the "EMER" position, the emergency hydraulic pump will be inoperative until the landing gear emergency control valve has been reset. This may be accomplished on the ground by manually resetting the valve arm located in the forward accessory compartment (figure 1-2, reference 25) or will be automatically reset on the next flight when the landing gear control (figure 1-3, reference 19) is moved to the "WHEELS UP" position. Gravity and air loads will extend the tail gear.

1-34. **BRAKES.** A power boost brake system operating from the main hydraulic system is provided. The brakes are operated by the pressure on the rudder brake pedals. In case of hydraulic system failure, pressure will be available for braking by exerting approximately twice the normal force on the rudder brake pedals.

1-35. **ARRESTING GEAR.** The arresting hook control (figure 1-3, reference 71) is located on the right-hand side of the cockpit. The hook may be lowered only from the cockpit and can be raised and latched manually on the ground only provided the control has been returned to the "HOOK UP" position after the landing has been completed. The approach light operates automatically in conjunction with the hook.

1-36. **TAIL WHEEL LOCK.** The tail wheel lock control (figure 1-3, reference 21) is located at the after end of the left-hand console panel.

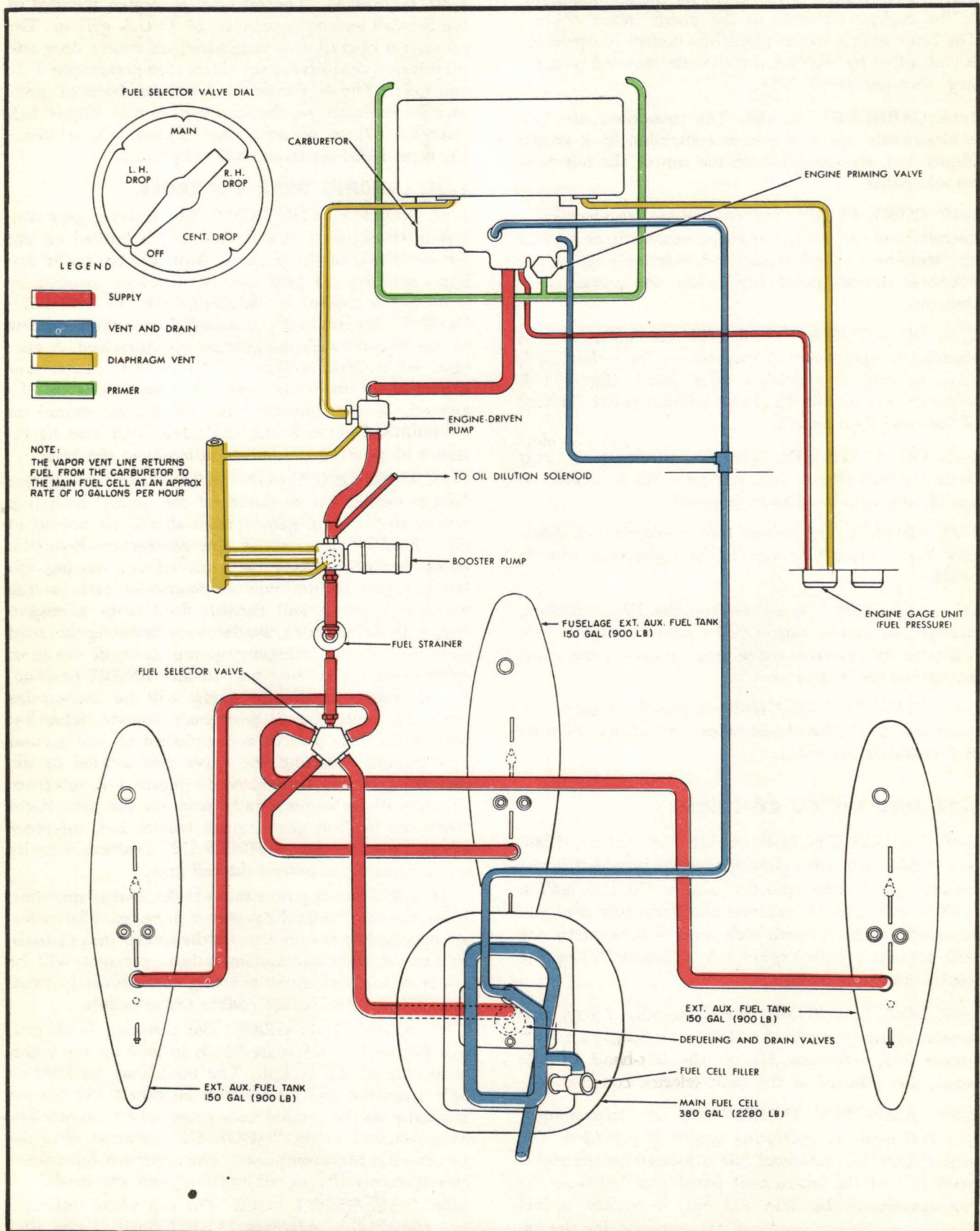

Figure 1-5. Fuel System Diagram

1-37. WING FOLDING.

1-38. WING FOLDING CONTROL. The wing folding control (figure 1-3, reference 77) is located on the right-hand vertical console panel. A door type control marked "WING FOLD," when moved to the normal (flat) position, operates the wing locking pins. The handle controlling the folding operation is located in a recess under the above handle. Both handles should be kept in the open ("unlocked" and "folded") positions at all times when the wings are folded.

1-39. HYDRAULIC SYSTEM CONTROLS.

1-40. GENERAL. The hydraulic system operates the landing gear, wing folding mechanism, wing flaps, dive brakes, wheel brakes, cockpit enclosure, and gun chargers. Power is normally supplied to the system by two engine-driven pumps through a pressure regulator which keeps system pressure at 2700 to 3000 psi, and a pressure accumulator. Hydraulic fuses are provided in the hydraulic system to prevent fluid from being pumped overboard in case of line failure.

1-41. EMERGENCY HYDRAULIC PUMP. An electrically-driven pump is provided for use in case of failure of the normal system and for checking the system on the ground when the engine is not running. The pump is controlled by the switch on the left-hand console panel and supplies fluid under pressure to the main system. When the landing gear control is placed in the "EMER" position, the landing gear emergency valve opens and the emergency hydraulic pump is automatically turned on, supplying fluid from the reserve supply in the reservoir to the main landing gear only. (See paragraph 1-33.)

1-42. ELECTRICAL SYSTEM CONTROLS.

1-43. BATTERY. A 24-volt, 30 ampere-hour battery is provided in the radio compartment in the aft end of the fuselage. The battery switch (figure 1-3, reference 88) is located on top of the right-hand console panel. The switch should normally be left on, but turned off when leaving the cockpit.

1-44. GENERATOR. The engine-driven generator supplies power for both the 28-volt d-c system and the 110-volt, 380-1760 cycle a-c system. The generator delivers full voltage at an engine speed of approximately 1550 rpm. A generator warning light (figure 1-3, reference 57) is provided on the instrument panel.

1-45. CIRCUIT BREAKERS. Circuit breakers for all electrical circuits are provided on the inboard side of the right-hand console unit. If a circuit becomes overloaded, its circuit breaker will automatically pop out. Operation of the circuit can be restored by pushing the breaker in, but it will not remain in until the cause of the overload is remedied.

1-46. EXTERNAL POWER RECEPTACLES. External power receptacles for both a-c and d-c power are provided under the fuselage near the leading edge of the wing. (See figure 1-2, reference 24.) The a-c receptacle automatically transfers from external to ship's power when the external power supply is disconnected.

1-47. MISCELLANEOUS.

1-48. PILOT'S SEAT ADJUSTMENT. An electrical actuator is provided for adjusting the pilot's seat up or down and is controlled by a switch (figure 1-3, reference 92) on the right-hand console panel. The seat moves in an arc upward and forward when raised.

Note

It is not possible to adjust the seat unless the generator is operating or an external power source is connected.

1-49. SHOULDER HARNESS ADJUSTMENT. The lower two free ends of the harness fit into the safety belt catch and are held securely as long as the catch is closed. To release the harness and safety belt, open the safety belt catch. Clips on the front of the harness permit it to be adjusted. An inertia reel shoulder harness take up mechanism is provided. The harness may be locked in position by pushing the handle (figure 1-3, reference 27) on the left side of the seat forward. In the unlocked position, the reel is automatically locked when subjected to an acceleration aft along the thrust line of the airplane (as in a head-on crash) in excess of 2.5g.

1-50. COCKPIT ENCLOSURE CONTROLS. The cockpit enclosure is hydraulically operated and is controlled by a lever (figure 1-3, reference 10) on the left side of the cockpit or a handle (figure 3-1, reference 2) accessible from outside the airplane on the left-hand side of the fuselage. When the airplane is on the ground with no pressure in the hydraulic system, the enclosure may be operated manually by moving the control to "OPEN" or "CLOSED" and sliding the enclosure to the desired position. With the hydraulic system functioning, move the control to the desired position. The enclosure may be left in any desired position by moving the control to "STOP." No provisions are made for jettisoning the enclosure. For operation of the enclosure emergency system, refer to paragraph 3-11.

1-51. PILOT GEAR RECEPTACLE. A receptacle for plugging in a pilot gear adapter is located at the after end of the left-hand console panel. It has provisions for connecting, simultaneously, the oxygen mask, suit heat, head phones, and microphone cord.

WARNING

This system is so designed, that should the pilot gear receptacle connector become disconnected, radio reception will fail and serve as a warning that the oxygen supply may be cut off.

1-52. OPERATIONAL EQUIPMENT.

1-53. GENERAL. Refer to Section IV for operation of the armament, oxygen, communications, electronic, heating, ventilating, and lighting equipment.

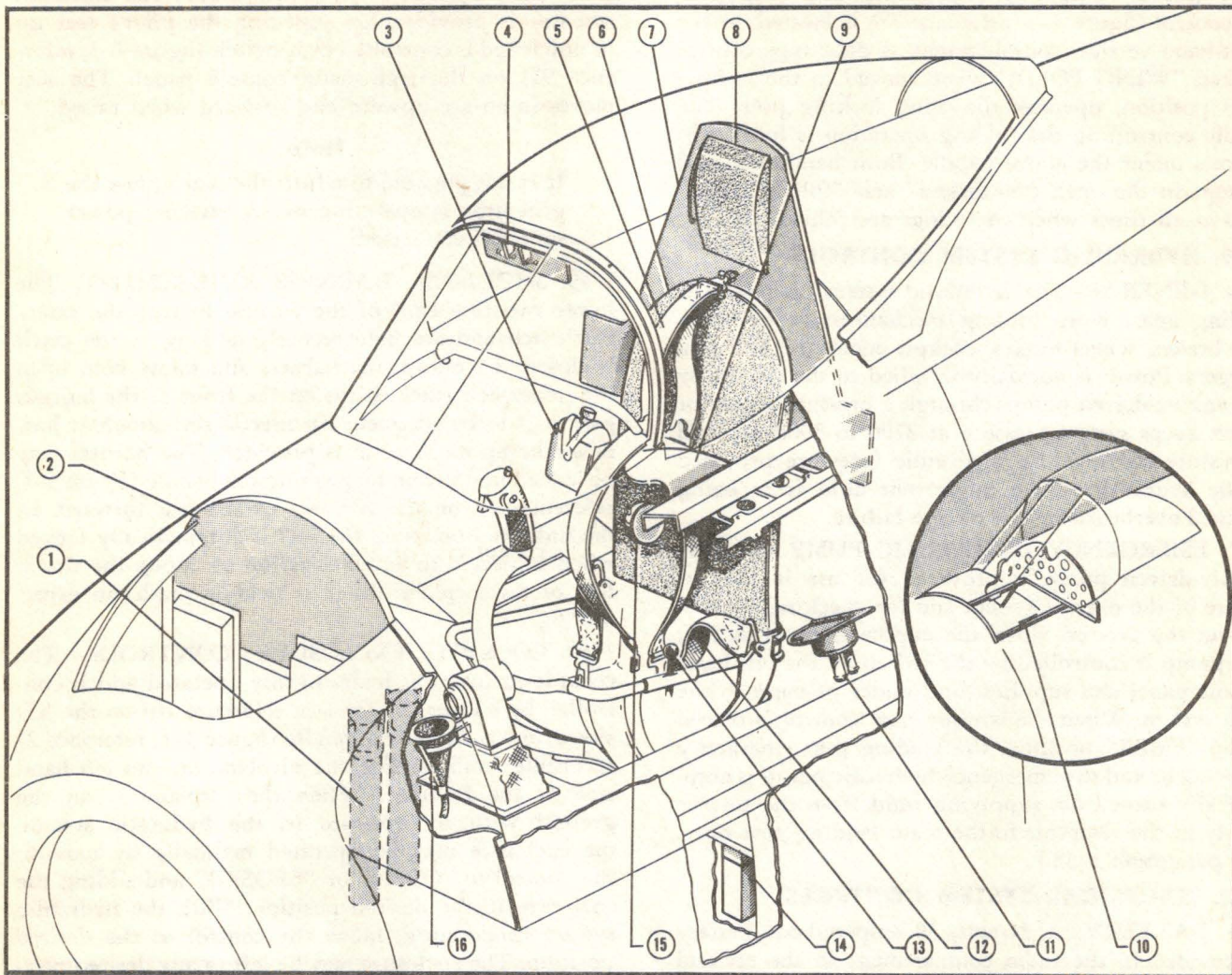

- 1. Night Drift Signals
- 2. Front Armor Plate
- 3. Canteen
- 4. Rear-View Mirror
- 5. Shoulder Harness
- 6. Back Pad
- 7. Back Armor Plate
- 8. Head Rest and Adjustment Cable

- 9. Arm Rest
- 10. Chart Board
- 11. Personnel Gear Receptacle
- 12. Lap Safety Belt
- 13. Shoulder Harness Control
- 14. Jack Pad Container
- 15. Ash Tray
- 16. Relief Tube

Figure 1-6. Miscellaneous Equipment Diagram

SECTION II

NORMAL OPERATING INSTRUCTIONS

2-1 BEFORE ENTERING THE COCKPIT

2-2. THE FOLLOWING RESTRICTIONS ARE TO BE OBSERVED IN THE OPERATION OF THE MODEL AD-2 SERIES AIRPLANES.*

a. The following maneuvers are permitted when *carrying* external load items:

- Vertical turn
- Wing over
- Aileron roll (only for entering a dive)
- Inverted flight (only for entering a dive)

b. The following maneuvers are permitted when *not carrying* external load items:

- Loop
- Chandelle
- Immelman turn
- Normal spin
- Aileron roll
- Inverted flight (only for entering a dive)
- Vertical turn
- Wing over

c. The maximum recommended gross weights for various operations are as follows:

Landing, prepared runways	18,000 lbs.
Landing, ordinary fields	15,800 lbs.
Catapulting	17,800 lbs.
Arrested landings, pilots qualified with AD aircraft	17,000 lbs.
Carrier qualification landings	15,600 lbs.

d. The maximum permissible combinations of airspeed and acceleration at a gross weight of 15,600 pounds or less are shown on figure 2-2. At gross weights above 15,600 pounds, the permissible accelerations are such as to maintain a constant product of acceleration and gross weight. The maximum speeds shown on figure 2-2 correspond to a Mach number of approximately .73. At Mach numbers between approximately .73 and .75, disturbances of controllability involving "tucking under," or tendency of the airplane to increase its dive angle, and other associated compressibility phenomena may be encountered. Mach numbers in excess of .75 have not been experienced, nor have serious compressibility effects.

e. Airspeed limitations for various operations are as follows:

OPERATION	AIRSPEED LIMITATION (KNOTS-IAS)		
	10,000 feet or below	20,000 feet	30,000 feet
(1) Opening dive brakes	350	290	235
(2) Lowering landing gear	350	290	235
(3) Lowering landing flaps	130	130	130
(4) Unrestricted use of ailerons	300	245	200

Note

At higher airspeeds the use of the ailerons shall be limited to the same stick force as is required for full throw at airspeed limitations listed opposite item (4) above.

f. The variation of permissible rudder pedal deflection with speed in yawing or skidding maneuvers (in terms of maximum pedal deflection available) is as follows:

PEDAL DEFLECTION	AIRSPEED LIMITATION (KNOTS-IAS)		
	10,000 feet or below	20,000 feet	30,000 feet
Full	260	215	175
$\frac{3}{4}$	330	270	220
$\frac{1}{2}$	395	335	275

g. Abrupt yawing and skidding maneuvers at speeds greater than 200 knots IAS shall not intentionally be performed; at these higher speeds, the rudder shall be applied and released smoothly and uniformly. The time for such application or release shall not intentionally be less than two seconds. Flight test information and design data for these airplanes indicate that more rapid applications or release will damage the structure.

h. When carrying any of the items listed below or similar items of less weight or combinations of these items, the airspeed and acceleration limitations are those given by figure 2-2, corrected for gross weight as described in paragraph 2-2e.

ITEM

- One torpedo or 2,000-lb. bom¹ on fuselage rack.
- One 150-gallon auxiliary fuel tank on fuselage rack.
- Two torpedoes or 2,000-lb. bombs on wing racks.
- Two 150-gallon auxiliary fuel tanks on wing racks.
- Two Tiny Tims (11.75" AR) on wing racks.
- Up to 12 HVAR on wing launchers (symmetrically loaded).

i. The maximum recommended unsymmetrical loading for take-off is equivalent to one full 150-gallon auxiliary fuel tank on the starboard wing rack and an AN/APS-4 radar on the port wing rack (representing a maximum unbalance of approximately 900 pounds on the starboard rack) or no load on the starboard rack and 300 pounds on the port rack. In combination with this unsymmetrical loading, a 2,000-pound bomb, torpedo, or lesser load can be carried on the fuselage bomb rack. Landings can be made with a 500-pound unsymmetrical loading, but only in emergencies. It is recommended that such unsymmetrical loads be jettisoned before landing.

j. Catapulting is permissible (a) with any symmetrical combination of the above listed stores or (b) with the maximum unsymmetrical loadings recommended

for take-off in paragraph 2-2i, subject to the gross weight limitations of paragraph 2-2c. Arrested landing is permissible with loads not exceeding one torpedo or 2,000-pound bomb on the fuselage rack, or with three 1,000-pound bombs, subject to the gross weight limitations of paragraph 2-2c. Arrested landings with one or more auxiliary fuel tanks are prohibited except when the tanks are empty.

k. In the interests of minimizing the severity of carrier landings from the standpoint of lessening vertical impact landing loads upon the airframe structure, it is recommended that high "cut" heights in combination with low airspeed at the time of cut be avoided. This should be done to as great an extent as is practicable and consistent with the other factors which determine the manner in which aircraft should be landed aboard with a maximum of safety and efficiency of operation. The following conditions for carrier landings are recommended:

- (1) The height above the deck at the time of cut should not be greater than 25 feet.
- (2) The airspeed at the time of cut should not be less than 12 knots above power-off stalling speed.
- (3) In general, carrier landing approach should be slightly fast and flat. Properly flared landings substantially reduce the severity of landing loads. Fully stalled landings should be avoided.

2-3. Check gross weight and center of gravity at take-off, and check anticipated loading for landing. Load-

ing data are furnished in the Handbook of Weight and Balance, AN 01-1B-40.

2-4. Check the exterior of the airplane for the following:

- a. General condition and cleanliness.
- b. Proper inflation of tires and struts. See that the arresting hook is latched up.
- c. Security of access door and cover plates.
- d. Check to see that pitot tube, air scoop, and any other external covers are removed.
- e. Check to see that any external locks or surface control battens are removed.
- f. Check quantity of hydraulic fluid, engine oil, water injection fluid, degreasing fluid, and ammunition on board.

2-5. ON ENTERING THE PILOT'S COCKPIT.

- a. Check the interior of the cockpit for general condition and for any loose items.
- b. Release the surface control lock.
- c. Battery switch—"ON." If available, plug in an external d-c power supply source.
- d. Adjust the seat and rudder pedals if necessary.
- e. Check the surface controls for freedom of movement.

*THESE LIMITATIONS AND RESTRICTIONS ARE SUBJECT TO CHANGE AND LATEST SERVICE DIRECTIVES AND ORDERS MUST BE CONSULTED.

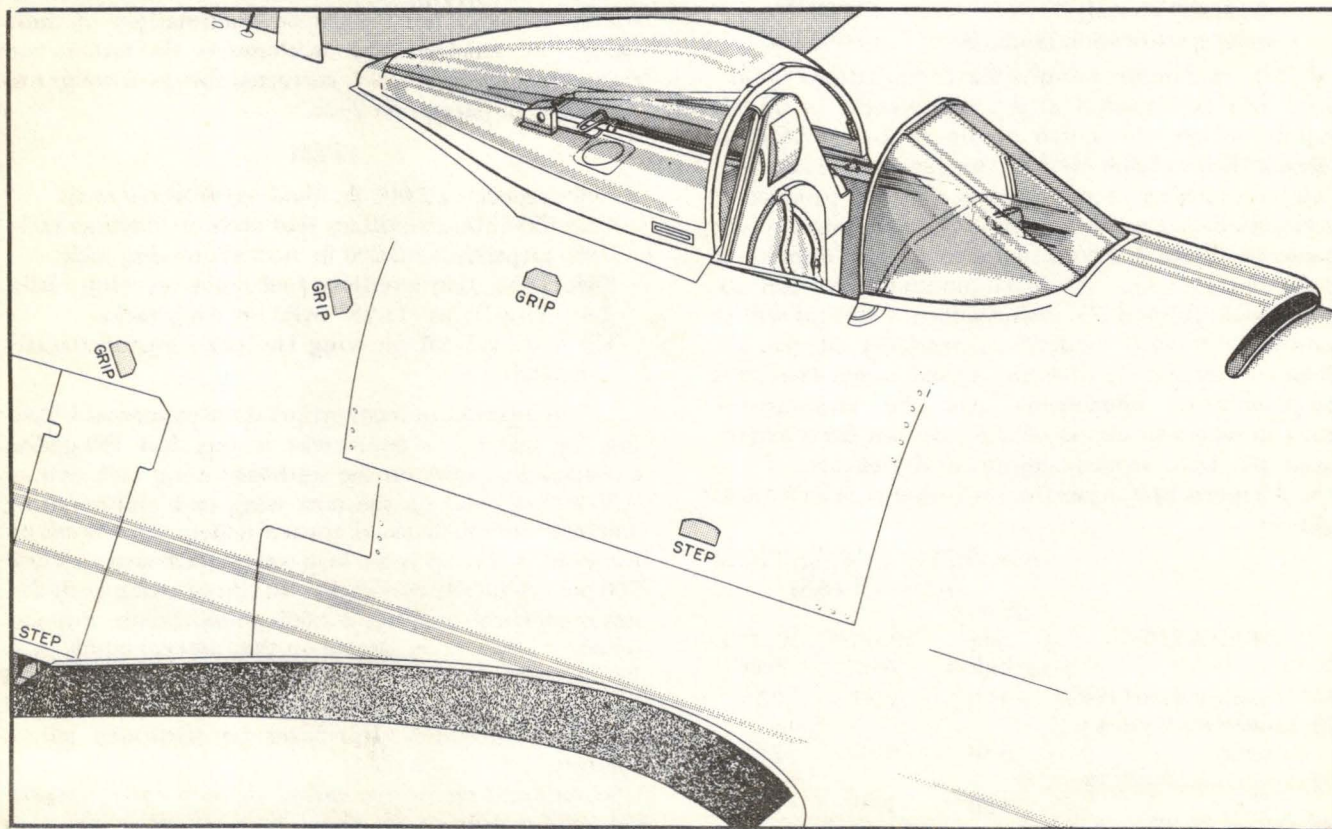

Figure 2-1. Entrance to Airplane

- f. Tail wheel—"LOCK."
- g. Horizontal stabilizer—"NOSE UP."
- h. Trim tabs—as desired.
- i. Wing flaps—"UP."
- j. Canopy—"OPEN."
- k. Dive brakes—"CLOSE."
- l. Landing gear—"WHEELS DOWN."
- m. Mixture control—"IDLE CUT-OFF."
- n. Ignition switch—"OFF."
- o. Armament master switch—"OFF."
- p. Uncage gyro instruments.
- q. Set altimeter and clock.
- r. Check gun sight light.
- s. Check oxygen equipment. (See paragraph 4-42.)
- t. Check bomb ejector system. (See paragraph 4-27.)
- u. If external a-c power source is available, check special electronic equipment. (See paragraph 4-71.)

Note

If an external a-c power source is not available, the special electronic equipment should not be checked until the engine is running.

2-6. CHECK FOR NIGHT FLIGHTS. Check the operation of all interior and exterior lights. Spare light bulbs are carried in a container in the right-hand console panel.

Note

The approach light may be checked by lowering the arresting hook. However, no provisions are made for raising the hook from the cockpit.

2-7. FUEL SYSTEM MANAGEMENT.

2-8. FUEL FLOW. Flow of fuel is controlled by the fuel tank selector valve. The main tank should be used for starting, warm-up, take-off, climb, and landing. When cruising altitude is reached, switch to one of the external auxiliary tanks, if installed. Fuel from the external auxiliary tanks should be used for level flight only. Switch back to the main tank for combat, maneuvers, and landing. The carburetor vapor vent returns to the main tank. Since this tank is used for starting, take-off, and climb, sufficient fuel will be used to avoid the possibility of the tank overflowing due to fuel returning through the vapor vent line.

2-9. FUEL BOOSTER PUMP. The fuel booster pump is used during starting, take-off, landing, and is also used to aid the engine-driven fuel pump in maintaining adequate fuel pressure at altitude or when a shift is made from one tank to another, and to serve as an emergency fuel pump in the event that the engine-driven pump fails.

2-10. SWITCHING FUEL TANKS. To switch from one fuel tank to another, fly the airplane level, turn the fuel booster pump "ON" and switch the fuel tank

selector to the desired tank and turn off the booster pump. Refer to paragraph 3-20 for directions for regaining suction if a tank runs dry.

Note

A fuel quantity indicator is not provided for the external auxiliary tanks.

2-11. JETTISONING EXTERNAL AUXILIARY FUEL TANKS. The external auxiliary tanks can be jettisoned by means of the electrical or manual release system.

WARNING

The manual release handle salvos all three racks simultaneously. If a bomb is installed on the fuselage rack, the tanks should be jettisoned electrically.

- a. For electrical release, set the bomb safety switch for the tank to be jettisoned to "BOMBS." See that the other two safety switches are "OFF."
- b. Set the bomb selector switch in the "ALL" position.
- c. Turn the master armament switch "ON."
- d. Depress the bomb release button on top of the control stick head to jettison the tank.

2-12. STARTING ENGINE.

- a. Check to see that the battery switch is "ON" and the ignition switch is "OFF."
- b. Cowl flaps—"OPEN."
- c. Oil cooler door—"AUTO."
- d. Carburetor air—"DIRECT."
- e. Propeller—"INCREASE" (low pitch).
- f. Supercharger—"LOW" blower. "HIGH" when outside air temperature is below 40°F.
- g. Mixture—"IDLE CUT-OFF."
- h. Fuel tank selector—"MAIN."
- i. Inch propeller through one revolution (4 blades) with engine starter and then turn through five more revolutions at normal starter speed.

CAUTION

The above procedure is necessary due to the possibility of damaging the engine due to excessive compression. If unusually high compression is present, remove the spark plugs from the lower cylinders and drain all liquid. Never turn the propeller opposite to engine rotation, as this may force liquid into the intake pipe from where it is apt to be drawn back into the cylinder when the engine is started.

- j. Throttle—Set for approximately 1200 rpm.
- k. Fuel booster pump—"ON." (Keep pump "ON" until engine-driven pump is supplying sufficient pressure.)
- l. Starter—Depress button (20 to 30 seconds maximum).
- m. Primer—Depress button as required.
- n. Ignition switch—"BOTH" after propeller has turned one revolution.
- o. Should the engine fail to start within 30 seconds, let the starter cool and then repeat the starting procedure.
- p. Mixture—"RICH" when the engine is firing smoothly on the primer. Continue to operate the primer intermittently as necessary.



The engine may "liquid lock" if it is not firing when the mixture control is moved out of the "IDLE CUT-OFF" position.

- q. Throttle—Reset for 1200 rpm. (Do not allow engine to exceed 1400 rpm on start.)
- r. Check the oil pressure. Stop the engine if the rear oil pressure does not register within ten seconds or does not reach 40 psi within 20 seconds. Head the airplane into the wind when ground operation for an extended period of time is anticipated.
- s. Refer to paragraph 3-2 for instructions to be followed in case of fire while starting.
- t. If the engine does not start, wait a few minutes to allow any spilled fuel to drain out of the blower drain. Inspection of the exhaust stack outlets should indicate whether the engine has been over-primed or under-primed. No trace of smoke indicates under-priming. Excessive black smoke indicates over-priming. The use of the primer switch should be governed accordingly. If the engine is over-primed, turn all switches off, open the throttle, put mixture control in "IDLE CUT-OFF" position, and turn the propeller through with the starter six revolutions.



Inch starter through on first revolution.

2-13. WARM-UP.

- a. Conduct a thorough warm-up at approximately 1200 to 1400 rpm before conducting any performance checks or before taxiing to take-off.
- b. For all ground operation, unless otherwise specified in paragraph 2-14, keep the cowl flaps "OPEN," the propeller in full "INCREASE" (low pitch) position, the mixture in "RICH," and the supercharger control in "LOW" blower.
- c. Continue the warm-up until the oil pressures stabilize.

2-14. GROUND TEST.

2-15. IGNITION SWITCH CHECK. At the start of the day's flying, the "OFF" position of the ignition switch should be checked to assure proper connection of the ground wires.

- a. Run the engine at approximately 700 rpm.
- b. Turn the ignition switch "OFF" momentarily to see if the engine stops firing.
- c. Return the switch to "BOTH."

2-16. MAGNETO CHECK.

a. Open the throttle to obtain 2300 rpm. This throttle setting, under sea level conditions, should result in a manifold pressure of approximately 30 inches Hg. Differences in pitch settings, atmospheric conditions, etc., will affect the manifold pressure required to obtain 2300 rpm; however, experience will indicate whether any variation from 30 inches Hg. is normal or one meriting further attention.



It is not advisable to check magnetos above 30 inches Hg. on the ground or in flight.

- b. Place the ignition switch in the "LEFT" position and observe the rpm.
 - c. Return the switch to "BOTH" to stabilize the engine speed.
 - d. Repeat this procedure for the "RIGHT" position.
 - e. Atmospheric conditions will influence the readings obtained. However, a drop of 75 rpm or less when operating on one magneto is considered satisfactory providing no engine roughness is encountered.
- 2-17. IDLE MIXTURE CHECK. With the engine idling at 600 rpm and the fuel booster pump "ON," move the mixture control slowly into "IDLE CUT-OFF" and observe any change in engine speed. Return the mixture control to "RICH" before the engine cuts out. A rise of more than ten rpm indicates too rich an idle mixture, and no rise or drop in engine speed indicates that the idle mixture is too lean. A rise of five to ten rpm is desired. This will permit idling at low speed without fouling the plugs and also affords good accelerating characteristics.

Note

While making the idle mixture check make sure that the cylinder head temperatures are at least 150°C.

2-18. PROPELLER CHECK.

- a. Run the engine at 1500 rpm but do not exceed 25 inches Hg. during the following check.
- b. Note rpm reaction as control is placed in full "DECREASE" (high pitch) position.
- c. Return the control to the full "INCREASE" (low pitch) position.
- d. Check for reduction and full recovery of rpm.

2-19. SUPERCHARGER CLUTCH CHECK.

- a. Set the engine speed at 1700 rpm with the throttle.
- b. Move the supercharger control to the "HIGH" position and lock.
- c. Open the throttle to obtain 30 inches Hg. manifold pressure.
- d. Move the supercharger control to the "LOW" position and lock. A sudden decrease in manifold pressure indicates that the two-speed mechanism is working properly.

CAUTION

Do not repeat supercharger clutch shift check at less than five minute intervals.

- e. Open throttle to see if 30 inches Hg. manifold pressure can be obtained in "LOW" position.

Note

The engine is equipped with a roller type clutch which does not need to be desludged.

2-20. OIL SYSTEM CHECK. Run the engine at 1500 to 1800 rpm. At an oil temperature of 85°C, the rear bank oil pressure should be 65 to 75 psi and the front bank oil pressure should be 50 to 60 psi.

2-21. FUEL SYSTEM CHECK. Check the operation of the engine-driven fuel pump by turning the booster pump switch "OFF" for a few minutes. Fuel pressure should be 19 to 21 psi. With the fuel booster pump "ON," fuel pressure should increase approximately one-half pound. If external auxiliary tanks are installed, the engine should be run on each tank long enough to see that all fuel lines are clear.

2-22. HYDRAULIC SYSTEM CHECK. The hydraulic pressure should be 2700 to 3000 psi.

Note

The hydraulic pressure gages installed in the airplane have a tolerance of ± 125 psi. This should be taken into account when checking the hydraulic system. No attempt should be made to reset the regulator or the relief valves with the airplane pressure gage.

2-23. ELECTRICAL SYSTEM CHECK. Check the operation of the electrical system as follows:

- a. Disconnect the external power source (if used) and see that the battery switch is "ON."
- b. With the engine idling, place a light load on the electrical system, such as instrument or cockpit lights.
- c. Increase the engine speed gradually until the voltmeter reads approximately 27 volts. If the generator warning light does not come on, it is an indication that the reverse-current relay is functioning properly.
- d. Increase the engine speed and check the voltmeter. The voltmeter reading should increase until it reaches

28 volts and remain at that reading regardless of any further increase in engine speed.

- e. A take-off should not be made if the generator warning light is on or if the voltmeter reading is too low (below 27.5 volts) or too high (above 28.5 volts).

2-24. ELECTRONIC EQUIPMENT CHECK. Refer to paragraph 4-70.

2-25. TAXIING.

2-26. The airplane is equipped with a conventional tail wheel type landing gear, and standard taxiing procedures should be followed. The controls should be set as follows for taxiing:

- a. Cowl flaps—"OPEN."
- b. Wing flaps—"UP."
- c. Mixture control—"RICH."
- d. Propeller control—"INCREASE" (low pitch).
- e. Carburetor air—"DIRECT." If icing conditions prevail, place the control in "ALTERNATE" until just before take-off.
- f. Tail wheel—"UNLOCK." Lock the tail wheel for extended cross-wing taxiing to relieve excessive braking action.
- g. The horizontal stabilizer control should be full "NOSE UP" and the elevators should be full up for all ground operations and taxiing to hold the tail down.

2-27. BEFORE TAKE-OFF.

2-28. GROUND AND CARRIER CHECK.

- a. Shoulder harness and safety belt—secured and locked.
- b. Tail wheel—"LOCK" (for ground take-off only) ("UNLOCK" for carrier take-off).
- c. Horizontal stabilizer control—0°.
- d. Dive brakes—"CLOSE."
- e. Aileron tab—0°.
- f. Rudder tab—5° right.
- g. Fuel booster—"ON."
- h. Fuel tank selector—"MAIN."
- i. Wing flaps—40° (full "DOWN").
- j. Supercharger—"LOW" blower.
- k. Landing gear—"WHEELS DOWN."
- l. Propeller control—"INCREASE" rpm (low pitch).
- m. Mixture—"RICH."
- n. Cowl flaps—"AUTO."
- o. Carburetor air—"DIRECT."
- p. Wings—Spread and locked.
- q. Battery switch—"ON." Leave battery switch "ON" during take-off, flight, and landing.
- r. Cockpit enclosure—"OPEN."
- s. Oil cooler door—"AUTO."
- t. External auxiliary tanks—Refer to paragraph 2-11 for positioning of controls in case of jettisoning.
- u. Run up engines.

WARNING

Under certain light loading conditions, the tail of the airplane will rise when the engine is operated at powers exceeding 28 inches Hg. at 2450 rpm and the wing flaps full "DOWN." When the wing flaps are "UP," engine run-ups should be limited to a maximum of 30 inches Hg. and 2650 rpm.

v. Check all instruments for indications within the required limits.

w. Cylinder head temperature—245°C maximum before take-off.

2-29. CATAPULT CHECK. In addition to the preceding checks, the following should be accomplished:

- a. Tail wheel—"LOCK."
- b. Tighten engine control friction adjustment knob.
- c. Place back and head firmly against back pad and headrest.
- d. Place feet against rudder pedals with legs stiff.
- e. Brace right arm.
- f. Push throttle forward and grasp static grip.

2-30. ENGINE POWER CHECK TABLE. The calibration below represents the correct manifold pressure for several carburetor air temperatures at a given rpm and altitude. (This table will be added when available.)

2-31. TAKE-OFF.

2-32. NORMAL TAKE-OFF.

- a. Flaps—40° (full "DOWN").
- b. Take-off speed—varies from 65 to 70 knots (75 to 80 mph) at 13,000 lbs. gross weight to 80 to 85 knots (92 to 97 mph) at 18,500 lbs.
- c. Stability—The airplane is inherently stable and has no unusual take-off characteristics.
- d. Refer to Appendix 1 for engine operating limits and take-off performance data.
- e. Refer to paragraph 2-3 for gross weight and loading restrictions.

2-33. MINIMUM RUN TAKE-OFF. For a minimum run take-off, the controls should be set in the same position as for a normal take-off and the airplane may be pulled off at an IAS varying from 63 knots (72 mph) at 13,000 lbs. gross weight to 78 knots (89 mph) at 18,500 lbs.

2-34. ENGINE FAILURE DURING TAKE-OFF. Refer to paragraph 3-9 for procedure to be followed in case of engine failure during take-off.

2-35. AFTER TAKE-OFF.

- a. Use brakes lightly to stop wheels from spinning.
- b. Retract the landing gear as soon as the airplane reaches a point beyond which a safe landing cannot be made in the field, or in any level space available for landing beyond the field.

Note

The landing gear will retract in a maximum time of five seconds.

c. Retract the wing flaps. The wing flaps will partially blow back automatically at air speeds above 109 knots (125 mph).

d. The friction knob should be adjusted to keep the engine controls from creeping during take-off.

2-36. CLIMB.

2-37. The characteristics of the airplane in a climb are normal. Refer to figures A-4 and A-7 for climbing speeds and powers.

2-38. Climb in "AUTO" position, but use the manual position if cylinder head temperature exceeds the following limits: above 2300 rpm, 245°C. Below 2300 rpm, 230°C. When operating at military power do not exceed 260°C. A material reduction in cylinder head and oil temperatures can be obtained by climbing at an IAS from 15 to 20 knots (17 to 23 mph) faster than best climbing speed. A tendency for oil to over-head can be checked more quickly by reducing engine speed than by throttling alone.

2-39. Booster pump "OFF" after climb is established unless engine pump alone does not maintain sufficient pressure (19 psi minimum).

2-40. DURING FLIGHT.

2-41. GENERAL. See the "Flight Operation Instruction Charts" (Figure A-8), Appendix 1, for effects on airplane performance due to changes in gross weight. See the "Power Plant Chart" (Figure A-4), Appendix 1, for engine operating data.

2-42. STABILITY. The airplane performs all ground and flight maneuvers with the normal characteristics of its type. In the cruising condition, the airplane has a high degree of stability at all permissible center of gravity locations.

2-43. USE OF TRIM TABS. The following procedure is recommended for trimming the airplane:

- a. Trim to the desired flight attitude with the horizontal stabilizer.

WARNING

Do not increase the indicated airspeed above 190 knots (220 mph) as long as the stabilizer is set for an airplane nose-up condition. This restriction is a design limitation.

b. Release the rudder pedals and hold the wings level with the stick. Center the needle of the turn and bank indicator, with the rudder trim tab.

c. Center the ball of the turn and bank indicator with the aileron trim tab.

d. If readjustment is necessary, repeat the above procedure.

2-44. ATTITUDE GYRO INDICATOR. This instrument is gyro stabilized and indicates the attitude of the airplane in pitch and bank. The gyro is universal, that is, it will not tumble regardless of the airplane's attitude at all times. Since it is universal, the gyro does not require caging and begins to operate as soon as the battery switch is turned on. Approximately three minutes are required for the gyro to reach normal operating speed after the battery switch is turned on.

2-45. G-2 COMPASS. This compass consisting of a gyro indicator on the panel and a remotely located amplifier and gyro stabilized transmitter. A caging switch for the indicator is incorporated in the instrument. Approximately five minutes are required for the gyro to reach normal operating speed after the battery switch is turned on. On heading changes the gyro will stabilize at the rate of three degrees per minute.

2-46. OPTIMUM CRUISING AND REDUCED AIRSPEEDS. Refer to "FLIGHT OPERATION CHARTS" (Figure A-8), Appendix 1, for the desirable settings of engine controls when the flying distance is predetermined, and for all the alternate cruising conditions.

2-47. POWER PLANT OPERATION. General smoothness, engine speed, manifold pressure, cylinder head temperature, oil temperature, and oil pressures give the most satisfactory indication of engine performance. If any one of these seems irregular, the engine should be throttled down, and if the cause is not apparent, a landing should be made to investigate the trouble.

2-48. POWER CONTROL. When the throttle is positioned to give a desired manifold pressure, the manifold pressure regulator (located between the linkage of the cockpit throttle control lever and the carburetor throttle lever) automatically maintains the selected manifold pressure at all altitudes below the critical altitude for the setting. If the critical altitude of the setting is exceeded, the engine performs in the same manner as any other engine operating at full throttle; pushing the throttle lever further forward will have no effect because the throttle valve in the carburetor is already wide open; power can only be increased by increasing engine speed.

WARNING

Pilots must be on the alert for atmospheric conditions that may cause carburetor icing. The normal drop in manifold pressure that occurs when the carburetor starts to ice is concealed because the manifold pressure regulator automatically opens the carburetor throttle to compensate for the loss in manifold pressure. Therefore, the pilot may receive no warning until the carburetor is heavily iced. Use of "ALTERNATE" air must be based on judgment rather than on any definite indication of icing:

When changing power, care must be taken to reduce manifold pressure *before* reducing rpm, and to increase rpm *before* increasing manifold pressure. The precaution is not necessary, however, in the low power cruising range where the same manifold pressure is recommended for all engine speeds of 1975 rpm or less.

2-49. MIXTURE CONTROL. "RICH" position shall be used during all ground operation and during take-off, approach and landing, "NORMAL" position may otherwise be used, provided cylinder head temperature is not excessive. If the engine shows a tendency to roughness during blower shifts or dives, the tendency will be lessened by shifting to "RICH" before making the shift or entering the dive.

2-50. SUPERCHARGER CONTROL. "HIGH" blower should not be used except at altitudes at which the desired power is not available in "LOW" blower. When operating at military or normal rated power, do not shift to "HIGH" blower unless not more than 36 inches manifold pressure can be obtained at full throttle in "LOW" blower; otherwise less power will be available in "HIGH" than could be obtained by remaining in "LOW." At lower powers, it is usually advantageous to obtain more power by increasing engine speed up to 2400 rpm in "LOW" blower before shifting to "HIGH."

2-51. To shift from "LOW" blower to "HIGH" blower.

a. Throttle—Reduce manifold pressure 4 inches Hg. to prevent exceeding desired manifold pressure after shifting to "HIGH."

b. Propeller control—Engine speed should be 2400 rpm or less, lower speeds being favorable to long clutch life. When justified by emergencies or tactical requirements, shifts may be made at 2600 rpm, but such shifts should be kept to a minimum.

c. Supercharger control—Shift rapidly to "HIGH." Be prepared to retard throttle to check any tendency of manifold pressure to rise excessively.

d. If engine shows a tendency to run roughly or to cut out during the shift, it is recommended that the mixture control be kept in "RICH" position for the duration of the blower shift.

2-52. To shift from "HIGH" blower to "LOW" blower.

a. Propeller control—Engine speed not over 2400 rpm unless justified by emergency or tactical requirement.

b. Supercharger control — Shift rapidly from "HIGH" to "LOW."

c. Advance throttle to obtain desired manifold pressure.

d. Any tendency of the engine to run roughly or cut out may be lessened by keeping the mixture control in "RICH" position for the duration of the shift.

Note

While the manifold pressure regulator is normally capable of maintaining any selected manifold pressure below critical altitude, it

should not be expected to control manifold pressure during a blower shift, because changes occur too rapidly for the regulator to follow, and the shift normally involves transition from full-throttle to part-throttle operation, or the reverse. Manual operation of the throttle is essential to proper control of manifold pressure during blower shifting.

2-53. COMBAT POWER. Although a manifold pressure regulator and other equipment for combat power operation are currently installed in the airplane, the engine has not been cleared for operation at combat rating, and therefore use of water injection is not authorized until tests have been completed and instructions for operation at combat rating have been released. The master switch should be kept in "OFF" position at all times. With the master switch "OFF," the manifold pressure regulator automatically limits the engine to military power, even though the throttle is pushed full forward.

2-54. ELECTRICAL SYSTEM CHECK. The electrical system should be checked in flight periodically as outlined in paragraph 2-23.

2-55. STALLS.

2-56. The stalling characteristics of the airplane in both the flaps up and flaps down conditions are normal and the stall is preceded by mild warning which begins two to four knots above the actual stall. With the flaps up the stall warning consists of a slight aileron "nibble" and with flaps down there is usually a general light buffeting of the tail surfaces in addition to the "nibble." At the stall the left wing usually drops and sometimes the nose pitches down at the same time. In power off stalls the airplane may stall without rolling but with power on a definite roll will normally be encountered. The important point is that, regardless of the type of stall experienced, the motion is not violent. Recovery from the stall is normal and is readily effected by use of the elevators and rudder when necessary to raise the low wing. Power-off stalling speeds

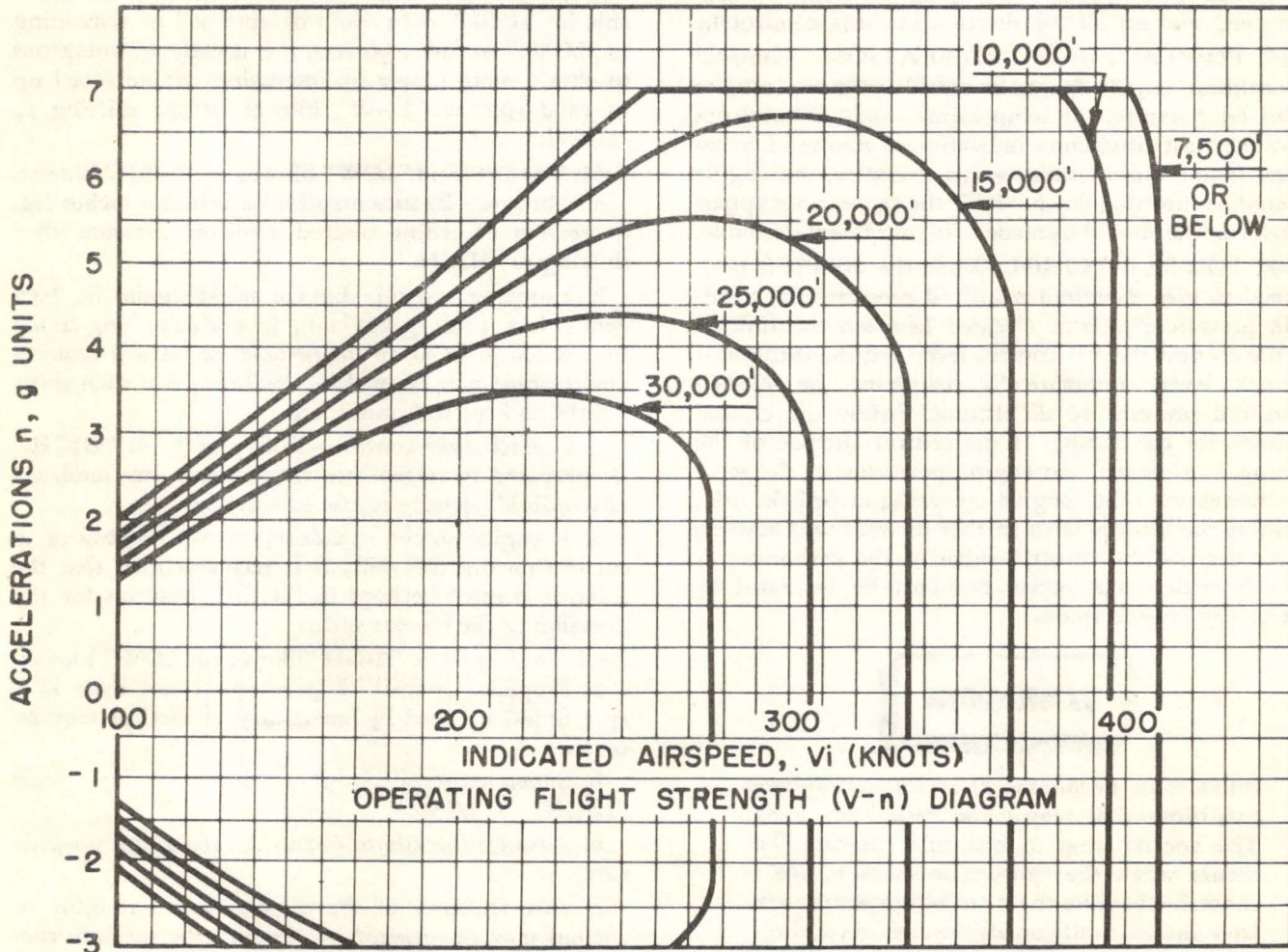

MODEL AD-2 SERIES AIRPLANES
GROSS WEIGHT = 15,600 LBS.

Figure 2-2. Operating Flight Strength Diagram

for various gross weights, landing gear, and flap positions may be found following this paragraph. Also see figure A-3, the Stalling Speed vs. Gross Weight Relationships chart. For banked turns corresponding to the normal traffic pattern approaches, the stalling speeds are increased two to five knots over corresponding values for level flight. The stall warning, actual stall, and subsequent recovery characteristics for banked turns are similar to those discussed preceding for stalls in level flight.

POWER-OFF STALLING SPEEDS
APPROX. INDICATED STALLING SPEEDS (Knots)

Gross Wt.	Flaps Up Gear Up	Flaps	Flaps Full
		Down (25°) Gear Down	Down (40°) Gear Down
12,000	76	69	66
14,000	82	75	71
16,000	87	80	76
18,000	93	85	80

2-57. SPINS.

2-58. Spinning characteristics of the airplane are normal and the standard procedure is recommended for best spin recovery. Spins to the right are on the order of steady, steep spins, while spins to the left are not as steep, tending to flatten out, causing oscillation and pitching. Spin recovery in the clean condition (flaps and gear up) is accomplished in less than one-half turn after primary recovery has been initiated. Approximately 1500 feet is required in the clean condition from the start of recovery to complete recovery (level flight). With the flaps and gear down, recovery is more rapid and more positive, with complete recovery being effected in less than one-third turn and a maximum loss in altitude of 1000 feet.

2-59. PERMISSIBLE ACROBATICS.

2-60. All normal maneuvers are permissible.

2-61. DIVING.

2-62. CONTROL SETTINGS. The controls should be set as follows for diving.

- a. Windshield defogger—"ALL TO WINDSHIELD" (at least 30 minutes before entering dive. See paragraph 4-100).
- b. Cockpit enclosure—Closed.
- c. Fuel tank selector—"MAIN."
- d. Mixture—"RICH."
- e. Supercharger—"LOW."
- f. Cowl flaps—"AUTO."
- g. Carburetor air—"DIRECT."
- h. Oil cooler door—"AUTO."
- i. Fuel booster pump—"ON."
- j. Horizontal stabilizer—"NOSE DOWN" ("DIVE" position on indicator).
- k. Trim tabs—As required (see paragraph 2-65).
- l. Propeller—2050 to 2250 rpm.
- m. Throttle—15 inches Hg.
- n. Dive brake—"OPEN."
- o. Landing gear—"WHEELS DOWN" if desired for additional braking. (See paragraph 1-10.)



Maximum allowable engine speed—3000 rpm (30-second limit).

2-63. ENGINE CONTROL DURING DIVE. To avoid faulty oil scavenging and to prevent the engine nose section from loading up with oil during prolonged dives at low engine speed, it is recommended that, when tactically possible, the propeller governor should be set for maximum cruising rpm plus or minus 100 rpm for all prolonged steep dives. A manifold pressure of 15 inches Hg. is recommended during prolonged dives. Any manifold pressure above 15 inches Hg. that is within engine limits for the engine speed, mixture control position, and altitude may be used. Higher manifold pressures increase diving speed. If manifold pressures much below 15 inches Hg. are held during a prolonged dive, the engine will foul up in the same manner as it does when the throttle is closed during prolonged glides. Sufficient manifold pressure should be used to keep the engine slightly warm and to burn away any oil that may pass the piston rings. Caution should be observed when diving from high altitude, since manifold pressure will build up rapidly at altitudes above the range within which the manifold pressure regulator can function. The throttle should be opened slowly at the completion of a dive so that the partly cooled engine will not cut out.

2-64. ENGINE OVERSPEEDING. If the engine overspeeds (exceeds the maximum limit of 3000 rpm), the throttle should be closed immediately, the propeller pitch increased, and the air speed reduced to minimum speed for a safe glide. While it is true that during overspeeding a high manifold pressure will cause explosive forces on the pistons, which will partly counteract the increased centrifugal forces on the bearings, closing the throttle will help to reduce the engine speed and thereby reduce the centrifugal forces more than they could be reduced by the explosive forces on the pistons.

2-65. DIVING TECHNIQUE. Before entering a dive, the trim tabs and horizontal stabilizer should be preset to give the desired trim of the airplane at that phase of a dive where the greatest precision and control are desired. It is practically impossible to set the tabs correctly after a dive has been started. In pulling out of a dive at the maximum allowable speed, full aileron action should be avoided. Severe or abrupt use of the ailerons above 300 knots (345 mph) IAS should also be avoided.



Do not use snap pull-outs in recovering from dives. Do not move the controls abruptly in any maneuvers at high speeds.

2-66. NIGHT FLYING.

2-67. Lights should be used as required. The proper use of oxygen during night flights is of particular importance. Oxygen should be used on all flights above 5,000 feet. (Refer to paragraph 4-42.)

2-68. APPROACH.

2-69. DESCENT.

- a. Landing gross weight—Refer to paragraph 2-2c.
- b. Shoulder harness and safety belt—Locked.
- c. Tail wheel—"LOCK" (for field)—"UNLOCK" (for carrier).
- d. Fuel booster pump—"ON."
- e. Fuel selector—"MAIN."
- f. Horizontal stabilizer—"NOSE UP" as required.
- g. Trim tabs—As desired.
- h. Cowl flaps—"AUTO."
- i. Check oil cooler door switch—"AUTO."
- j. Mixture—"RICH."
- k. Supercharger—"LOW" blower and locked.
- l. Dive brake—"CLOSE."
- m. Master armament switch—"OFF."
- n. Gun chargers—"OFF."
- o. Carburetor air—"DIRECT."
- p. Propeller 2150 rpm.
- q. Cockpit enclosure—Locked "OPEN."

2-70. FINAL APPROACH.

- a. Lower flaps and gear when IAS is below 130 knots (150 mph).
- b. Make a normal approach at approximately 75 to 80 knots (86 to 92 mph) IAS.

2-71. LANDING.

2-72. NORMAL LANDINGS.

2-73. SHORE LANDINGS. Use flaps as desired. Full flaps (40°) should normally be used. Lesser flap settings will result in increased landing speed, and hence increased ground run.

2-74. CARRIER LANDINGS. Lower the arresting hook. Full flaps (40°) should be used for all carrier landings. Standard carrier approach and landing procedures should be followed.

WARNING

Do not return the arresting hook control to the "HOOK UP" position until the airplane has come to rest on deck.

2-75. AFTER LANDING.

- a. Raise the landing flaps immediately upon completion of the landing roll.

- b. Cowl flaps — "OPEN."
- c. Propeller control — High rpm (low pitch).

Note

All taxiing should be done with the controls in the above positions.

2-76. SPECIAL LANDINGS.

2-77. CROSS WIND LANDINGS. Cross wind landings can best be made by landing with the tail slightly up and somewhat less than normal flap angle. All other controls should be in the same position as for normal landings. Use some downwind rudder just prior to contact with the ground to head the airplane in the direction of motion over the ground. During the run after landing, there will be a tendency for the upwind wing to rise, and the airplane will turn into the wind. Use a little rudder or brake for counter-action.

WARNING

Use brakes cautiously until the tail wheel is on the ground.

2-78. MINIMUM RUN LANDINGS. Use full flaps with the propeller in high rpm (low pitch) and the throttle slightly open. The approach should be rather flat as in a carrier landing; the nose should be high. Bring the airplane in about ten feet above the runway, close the throttle, and drop the airplane to the runway. Use the brakes as necessary.

2-79. EMERGENCY LANDING PROCEDURES. Refer to paragraph 3-13.

2-80. TAKE-OFF IF LANDING IS NOT COMPLETED.

- a. Open the throttle slowly and smoothly.
- b. Move propeller to full "INCREASE" rpm (low pitch).
- c. Raise the landing gear.
- d. Raise the landing flaps after minimum safe altitude has been obtained.
- e. Reduce power as required.

2-81. STOPPING THE ENGINE.

- a. Idle the engine at 1000 rpm to allow cylinder head temperature to cool below 150°C.
- b. Propeller control — "INCREASE" rpm.
- c. Booster pump — "OFF."
- d. Mixture control — "IDLE CUT-OFF."
- e. Engine ignition switch "OFF" after propeller stops rotating.
- f. Check cowl flaps — "OPEN."

2-82. OIL DILUTION. If temperature below $+2^{\circ}\text{C}$ (35°F) are anticipated, the oil must be diluted as follows:

Note

Oil dilution is not effective at temperatures above 70°C .

a. Request ground crew member to open the oil dilution shut-off cock, located at the bottom of the oil tank. (See figure 1-2, reference 14).

Note

The above shut-off cock is normally wired in the closed position, but for continued cold weather operation may be left in the open position.

b. Operate engine at 1000 to 1200 rpm. Accelerate for 10 seconds at the end of the dilution period.

c. Maintain oil temperature below 50°C and the oil pressure above 15 psi.

d. Hold oil dilution switch in "OIL DILUTION" position according to the following table:

- 4°C to -12°C (40° to 10°F) — 4 minutes
 - -12°C to -29°C (10° to -20°F) — 6 minutes
 - -29°C to -46°C (-20° to -50°F) — 9 minutes
- Add one minute dilution for each additional 5°C (9°F) below -46°C .

e. Mixture control — "IDLE CUT-OFF" (after two minutes — to stop engine).

f. Ignition switch — "OFF."

g. Oil dilution switch — "OFF." (After propeller stops turning.)



CAUTION

If the oil pressure of a cold engine started after oil dilution fluctuates or drops after running a short time, the oil dilution switch should be moved to "OIL DILUTION" for intervals of a few seconds. If the oil pressure does not steady out, stop the engine and wait at least five minutes before attempting another start. The oil supply of an engine in which the oil has been diluted should be checked after a thorough warm-up.

2-83. BEFORE LEAVING THE AIRPLANE.

- a. Turn the fuel tank selector "OFF."
- b. Turn off all electrical switches.
- c. Uncage the gyro instruments.
- d. Landing gear — "WHEELS DOWN."
- e. Wing flaps — "UP" (0°).
- f. Dive brakes — "CLOSE."

2-90. MOORING.

- a. Install surface controls lock. (See paragraph 1-6.)
- b. Chock wheels.
- c. If gusty wind conditions prevail, tie the airplane down. (See figure 2-3.)

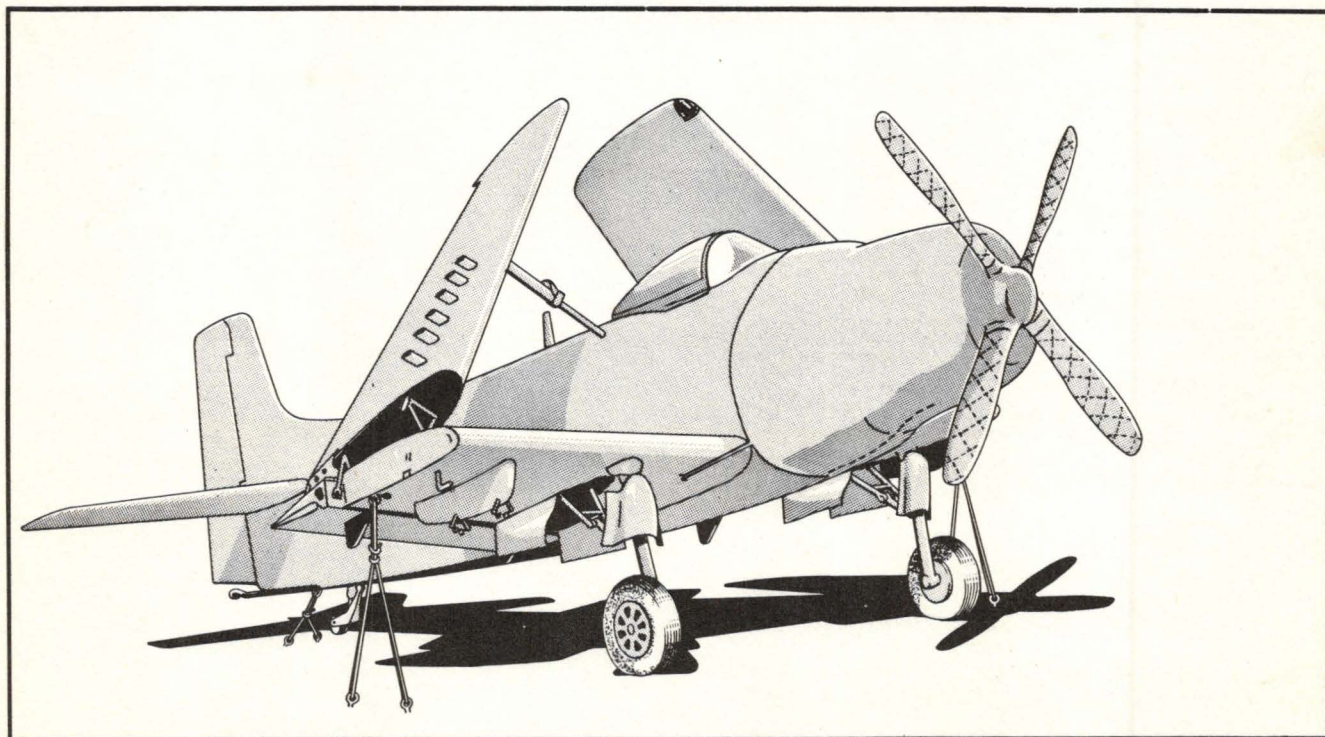

Figure 2-3. Mooring

1. The purpose of this document is to provide a detailed description of the system and its components. This section will cover the overall architecture, the various modules, and the data flow between them. It is intended for use by system administrators and developers who need to understand the internal workings of the system.

2. The system is designed to be highly scalable and flexible, allowing it to handle a wide range of data and user requirements. It is built on a robust foundation of industry-standard technologies, ensuring reliability and performance. The architecture is modular, allowing for easy integration with other systems and the addition of new features over time.

3. The system is designed to be secure and compliant with all applicable regulations. It includes a comprehensive set of security controls, including authentication, authorization, and auditing. The system is also designed to be highly available, with built-in redundancy and failover mechanisms to ensure that it is always up and running.

4. The system is designed to be easy to use and maintain. It includes a user-friendly interface and a comprehensive set of documentation. The system is also designed to be highly configurable, allowing users to tailor the system to their specific needs. The system is also designed to be highly extensible, allowing for the addition of new features and functionality over time.

5. The system is designed to be highly reliable and stable. It is built on a solid foundation of proven technologies and has been thoroughly tested to ensure that it can handle the most demanding workloads. The system is also designed to be highly secure, with a comprehensive set of security controls that protect against all known and unknown threats.

6. The system is designed to be highly flexible and adaptable. It is built on a modular architecture that allows for easy integration with other systems and the addition of new features over time. The system is also designed to be highly configurable, allowing users to tailor the system to their specific needs.

7. The system is designed to be highly extensible and scalable. It is built on a robust foundation of industry-standard technologies, ensuring reliability and performance. The system is also designed to be highly available, with built-in redundancy and failover mechanisms to ensure that it is always up and running.

8. The system is designed to be highly secure and compliant with all applicable regulations. It includes a comprehensive set of security controls, including authentication, authorization, and auditing. The system is also designed to be highly available, with built-in redundancy and failover mechanisms to ensure that it is always up and running.



SECTION III

EMERGENCY OPERATING INSTRUCTIONS

3-1. FIRE.

3-2. FIRE WHILE STARTING ENGINE. Backfiring sometimes causes fire in the induction system as a result of the presence of excessive fuel after priming. Allowing the engine to run will often cause the fire to be drawn out through the engine. If the fire continues, place the mixture control in "IDLE CUT-OFF," turn the ignition switch and fuel tank selector to "OFF" and vacate the airplane. An outside portable fire extinguisher should then be used to quench the fire.

3-3. FIRE DURING TAKE-OFF. If a fire occurs during take-off, a landing should be made as quickly as possible.

3-4. FIRE DURING FLIGHT. The best means of preventing engine fire is through a rigid ground inspection and maintenance of those items which might

fail and cause a fire. If altitude and other factors permit, the following steps should be carried out. However, it is left to the pilot's discretion whether to attempt to extinguish the fire or to bail out.

- a. Place the propeller in "DECREASE" rpm (high pitch).
- b. Close the throttle (simultaneously with a., above).
- c. Turn fuel selector "OFF."
- d. "OPEN" cowl flaps.
- e. Move mixture control to "IDLE CUT-OFF."
- f. Turn off ignition.
- g. Turn off electrical switches.
- h. Lower landing gear if practicable (if the tires are in the path of the flames when retracted).
- i. DO NOT RESTART ENGINE.

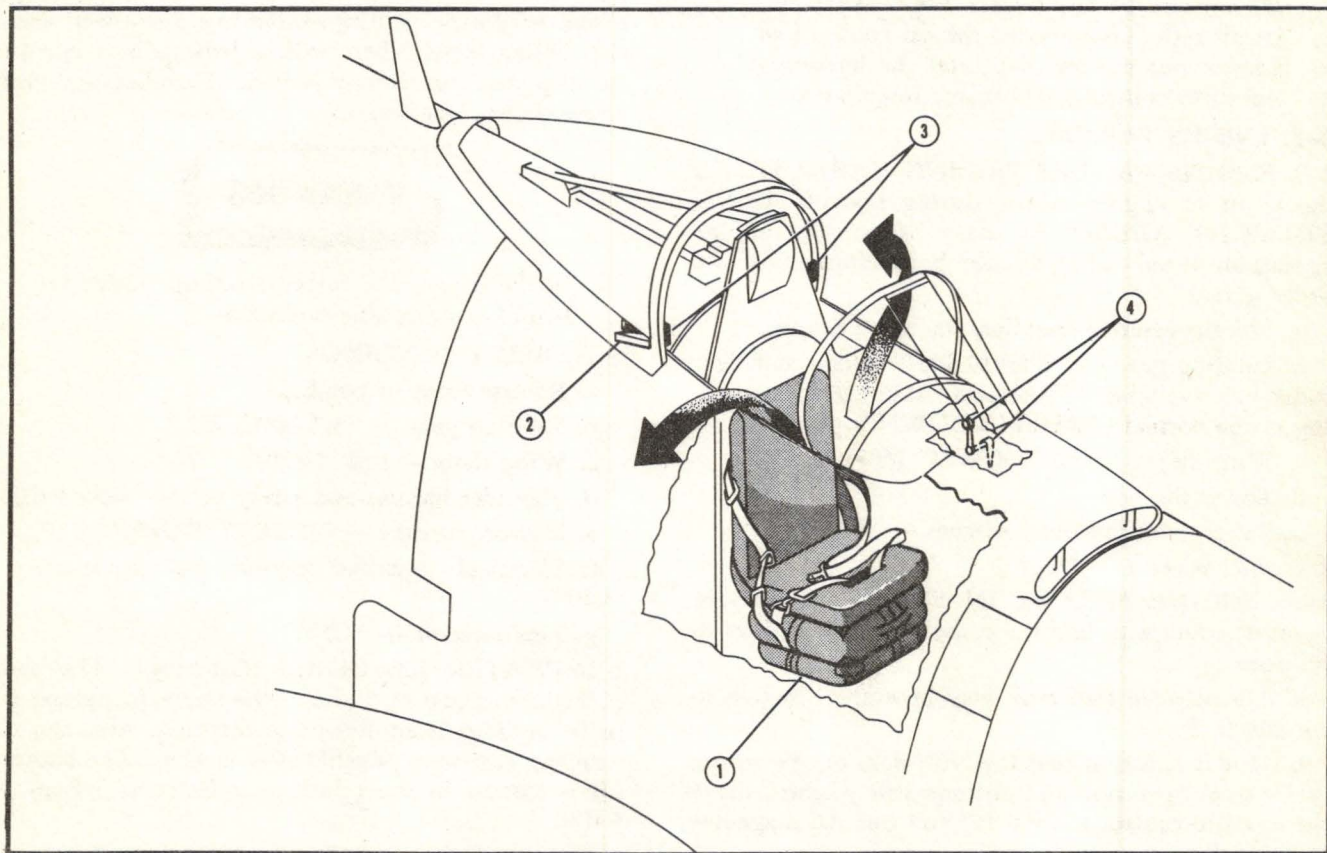

1. Parajump Kit
2. Enclosure Exterior Manual Operating Handles (Typical Both Sides)
3. Enclosure Interior Manual Operating Handles
4. Enclosure Exterior and Interior Hydraulic Locking Controls

Figure 3-1. Emergency Equipment and Exits

3-5. ELECTRICAL FIRES. In the event of a fire in the electrical system, the following procedure should be applied:

- a. Turn off the battery switch.
- b. Turn off all other electrical equipment.
- c. If the fire is extinguished, turn the circuits on one at a time, starting with the battery switch, and watch for the circuit which causes the fire.

3-6. WING FIRE.

- a. Release external auxiliary fuel tank and bombs.
- b. If a wing fire occurs during night flight operation, turn the switches which control all the lights within the wing "OFF."
- c. Attempt to extinguish the fire by side-slipping the airplane away from the wing fire.

3-7. FUSELAGE FIRE. If the fire is due to a leaking fuel line turn the fuel selector valve to an applicable tank if external auxiliary tanks are carried.

WARNING

Do not turn battery switch "OFF" as the electrical flight instruments, the oil cooler door, booster pump, cowl flaps and the horizontal stabilizer control will become inoperative.

3-8. ENGINE FAILURE.

3-9. ENGINE FAILURE DURING TAKE-OFF. On the event of engine failure during take-off, LAND STRAIGHT AHEAD. As many as possible of the operations listed below should be performed in the order given.

- a. Release external auxiliary tanks or bombs.
- b. Landing gear — "WHEELS UP" unless sufficient runway is available STRAIGHT AHEAD for a landing in the normal ("WHEELS DOWN") position.
- c. Wing flaps — full "DOWN" (40°).
- d. Lower the seat.
- e. Battery and ignition switches — "OFF."
- f. Fuel selector — "OFF."

3-10. ENGINE FAILURE IN FLIGHT. If altitude permits, attempt to find the cause of engine failure as follows:

- a. The selected fuel tank may be empty. Switch to another tank.
- b. If it is apparent that the fault does not lie in the fuel system operation and altitude still permits, move the mixture control to "RICH" and test the magnetos individually.
- c. If, after completing the above operations, the engine does not start, prepare for an emergency landing. See paragraph 3-13 following.

Note

The maximum gliding ratio is 12.6 at approximately 120 knots (138 mph) IAS.

3-11. ESCAPE FROM AIRPLANE.

3-12. No provisions are made for jettisoning the enclosure. An accumulator is provided in the enclosure hydraulic system for emergency opening of the enclosure in case of hydraulic system failure. To operate the enclosure emergency system, move the control handle to the "EMERGENCY" position.

3-13. FORCED LANDING.

3-14. GENERAL. In the event of a forced landing over land, the pilot should consider a number of variables in order to determine his best landing attitude. These include altitude, type of terrain, and the characteristics of the airplane. Landings in terrain such as golf courses, ploughed fields, swamps, mud, or sand should be made with the wheels up. Most nose-overs occur as a result of landing in such territory with the landing gear down, and nearly all serious injuries and fatalities result from nosing over. Landings in rough, rocky, or tree stump terrain should be made with the wheels down so that the landing gear and not the fuselage will make the initial contact. Pilots should remember that ground which appears smooth and level from the air frequently turns out to be rough, crossed with ditches, soft, or full of obstructions when the actual landing is made. All forced landings should be made well above the stalling speed. There will be little or no control of the airplane if an attempt is made to land at or slightly above the stalling speed.

WARNING

In the event of a forced landing, release all bombs or droppable tanks first.

3-15. BELLY LANDINGS.

- a. Release tanks or bombs.
- b. Landing gear — "WHEELS UP."
- c. Wing flaps — full "DOWN" (40°).
- d. Shoulder harness and safety belt — locked tight.
- e. Mixture control — "IDLE CUT-OFF."
- f. Electrical switches (battery and ignition) "OFF."
- g. Fuel selector — "OFF."

3-16. WATER LANDINGS (Ditching). The same procedure as that outlined in the above paragraph for belly landings is applicable to ditching. Abandon the airplane as soon as possible after landing. The paraft kit is stowed in the pilot's seat. Refer to paragraph 3-42.

3-17. PROPELLER EMERGENCY OPERATION

3-18. RUNAWAY PROPELLER. Failure of the governor to operate properly may result in a runaway propeller. A runaway propeller goes to full low pitch and may result in an engine speed as high as 3600 rpm or more. When such a failure occurs, the only method of reducing the engine speed is to throttle back and

decrease the airspeed. In doing this, it is highly important to make use of the allowable maximum overspeed of 3000 rpm and to reduce the IAS to approximately 120 knots (138 mph), the practical operating speed at minimum power.

3-19. FUEL SYSTEM EMERGENCY OPERATION.

3-20. REGAINING LOST SUCTION. If suction is lost, proceed as follows:

- a. Check position of fuel tank selector and set to tank containing fuel.
- b. Turn fuel booster pump "ON."
- c. Retard throttle to $\frac{1}{4}$ position. The engine should never be started at full throttle, since a momentary, but serious, overspeeding of the engine would result.

Note

If suction is only partially lost and is not accompanied by complete engine cut-out, the above steps may be sufficient to re-establish suction. If not, continue as follows:

- d. Move mixture control to "IDLE CUT-OFF" until adequate fuel pressure is built up, then move to "RICH" to prevent premature starts and backfiring.
- e. Nose the airplane over into a steep glide to provide adequate maximum gravity flow to booster pump and to provide adequate speed for engine-driven fuel pump by windmilling.
- f. Use primer as necessary until engine is firing smoothly.

3-21. ENGINE-DRIVEN PUMP FAILURE. In case the engine-driven fuel pump fails, turn the booster pump "ON" to furnish fuel pressure.

3-22. JETTISONING EXTERNAL AUXILIARY FUEL TANKS. See paragraph 2-11.

3-23. COURSES OF FUEL FLOW. See figure 1-4.

3-24. SYSTEMS AND CONTROLS EMERGENCY OPERATION.

3-25. MAIN HYDRAULIC SYSTEM OPERATION. In case of engine-driven hydraulic pump failure, the hydraulically controlled units may be operated by the emergency hydraulic pump. (See paragraph 1-41.)

3-26. LANDING GEAR EMERGENCY EXTENSION. If the engine-driven hydraulic pump has failed, the landing gear may be lowered by putting the control in the "WHEELS DOWN" position and operating the emergency hydraulic pump. If the gear does not extend, it indicates that there is probably not enough fluid in the reservoir. An emergency supply of fluid, available only for lowering the main landing gear, is provided below the standpipe in the main fluid supply line in the reservoir. To extend the gear, place the landing gear control in the "EMER" position. This procedure will extend the main wheels only; the tail wheel may remain retracted.

WARNING

If the landing gear control has been moved to the "EMER" position, manually reset the landing gear emergency control valve on the ground or automatically reset it on the next flight by moving the landing gear control to the "WHEELS UP" position. When the airplane is on the ground, make sure that the main hydraulic system pressure is zero or the main landing gear will retract.

3-27. EMERGENCY BRAKE OPERATION. The brakes are operated by a power boost system from the main hydraulic system. In case of loss of hydraulic system pressure, the brakes may be operated by normally depressing the rudder brake pedals; however, approximately twice the foot pressure will be required.

3-28. WING FLAP AND DIVE BRAKE EMERGENCY OPERATION. If the engine-driven hydraulic pump fails, the wing flaps or dive brakes may be operated by placing the control in the desired position, and operating the emergency hydraulic pump. If the dive brake control lever cannot be moved to the "OPEN" position, release the safety solenoid. (See paragraph 3-33.)

3-29. AILERON POWER BOOST EMERGENCY RELEASE. In case of hydraulic system failure and excessive control forces are present, the aileron power boost system may be disconnected by pulling the emergency release handle.

3-30. ELECTRICAL SYSTEM EMERGENCY OPERATION.

3-31. If high voltage (over 30.0 volts) occurs it indicates a failure in the generator circuit. The battery switch should be turned off to prevent burning out the battery and other equipment.

3-32. Low Voltage (below 26.0 volts). Low voltage may permit the reverse current relay to open and allow the electrical equipment to drain the battery. If the generator warning light comes on it is an indication that the reverse current relay is open, and all but absolutely essential electrical loads should be turned off in order to conserve the battery power.

3-33. LANDING GEAR AND DIVE BRAKE SAFETY SOLENOIDS. A safety circuit containing a solenoid for the landing gear and one for the dive brakes keeps the control levers from being moved to the "WHEELS UP" (landing gear) or "OPEN" (dive brakes) positions when the landing gear is extended and the weight of the airplane is on the shock struts (struts compressed). If the circuit fails in flight and it is desired to raise the gear or extend the dive brakes, the solenoid locks may be released by operating the solenoid release lever adjacent to each control lever.

3-34. CIRCUIT BREAKERS. For location of circuit breakers see figure 1-2, reference 12.

3-35. RADIO EQUIPMENT EMERGENCY OPERATION.

3-36. AN/APX-2 EQUIPMENT. In case of a forced landing or an emergency, the AN/APX-2 master switch should be placed in the EMERGENCY position by pushing the stop and turning the switch to the extreme clockwise position. This causes the transponder to send out a special emergency or distress signal. In case of a forced landing in questionable territory, the equipment should be destroyed by raising the guard and closing the destructor switch. In case of a crash landing, an impact switch automatically sets off the destructor circuit; however, as a safety precaution, the destructor switch should always be closed if time permits.

3-37. ARMAMENT EQUIPMENT EMERGENCY OPERATION. To salvo the bombs or torpedoes, with the electrical system operative, proceed as follows:

- a. Armament master switch—"ON."
- b. Bomb safety switches—"BOMBS."
- c. Arming switches—As desired.
- d. Bomb selector switch—"ALL."
- e. Depress release buttons on control stick head.

3-38. MANUAL BOMB AND TORPEDO RELEASE. If the electrical system is inoperative, the bombs or torpedo on all three racks can be salvoed manually by pulling the emergency release lever on the inboard side of the left-hand control panel. Since the bomb

ejector system does not operate when the manual release is used, the airplane must be level flight before the bombs or torpedo are dropped.

3-39. OXYGEN EQUIPMENT EMERGENCY OPERATION.

3-40. OXYGEN REGULATOR. In an emergency, or if the diluter-demand regulator becomes inoperative, the emergency valve control (red knob marked "EMER.") can be used to supply a steady flow of 100 percent oxygen. The control should be turned slowly counterclockwise to obtain the minimum flow required.

3-41. MISCELLANEOUS EMERGENCY EQUIPMENT.

3-42. PARARAFT KIT. The seat is designed to accommodate a type PK-2 pararaft kit (figure 3-1, reference 1) and a QAS parachute. The parachute is operated in the usual manner by pulling the rip cord handle on the left retainer strap. After descending to land or into water, the pararaft kit should be separated from the harness by removing the release link on the container and pulling out the kit by the handle provided for that purpose.

Note

The pararaft should be attached to the life vest or belt by means of the lanyard provided. The pararaft may be lost after the parachute harness is removed if this attachment is not correctly made.

SECTION IV

OPERATIONAL EQUIPMENT

4-1. ARMAMENT EQUIPMENT.

4-2. GENERAL. The airplane is designed to carry two 20-mm guns, twelve rockets, and various combinations of bombs, mines, torpedoes, etc., on the three bomb racks.

4-3. ARMAMENT MASTER SWITCH. The armament master switch (figure 4-1, reference 14) controls the operation of all armament equipment. Unless this switch is "ON," no armament circuits can be energized. The master armament circuit is automatically opened when the arresting hook is extended.

4-4. GUNNERY EQUIPMENT.

4-5. DESCRIPTION. Two forward firing 20-mm guns are mounted in the center wing panel, one at each folding joint. A gun sight is provided and may be used as a bomb and torpedo sight. Provisions have been made for mounting a gun camera in the leading edge of the right-hand wing.

4-6. GUNNERY CONTROLS.

4-7. GUN SIGHT CONTROLS. The gun sight switch and rheostat are located on the left-hand side of the armament console panel (figure 4-1, references 1 and 2). A Mark 18, Mod. 1 control box is installed on the left-hand console panel.

4-8. GUN CHARGING SWITCH. This switch is located on the armament control panel (figure 4-1, reference 3).

4-9. OPERATION OF GUNNERY EQUIPMENT.

4-10. TO OPERATE THE GUN SIGHT.

- a. Battery switch—"ON."
- b. Armament master switch—"ON."
- c. Gun sight switch—"ON."
- d. Adjust rheostat to desired brilliance.

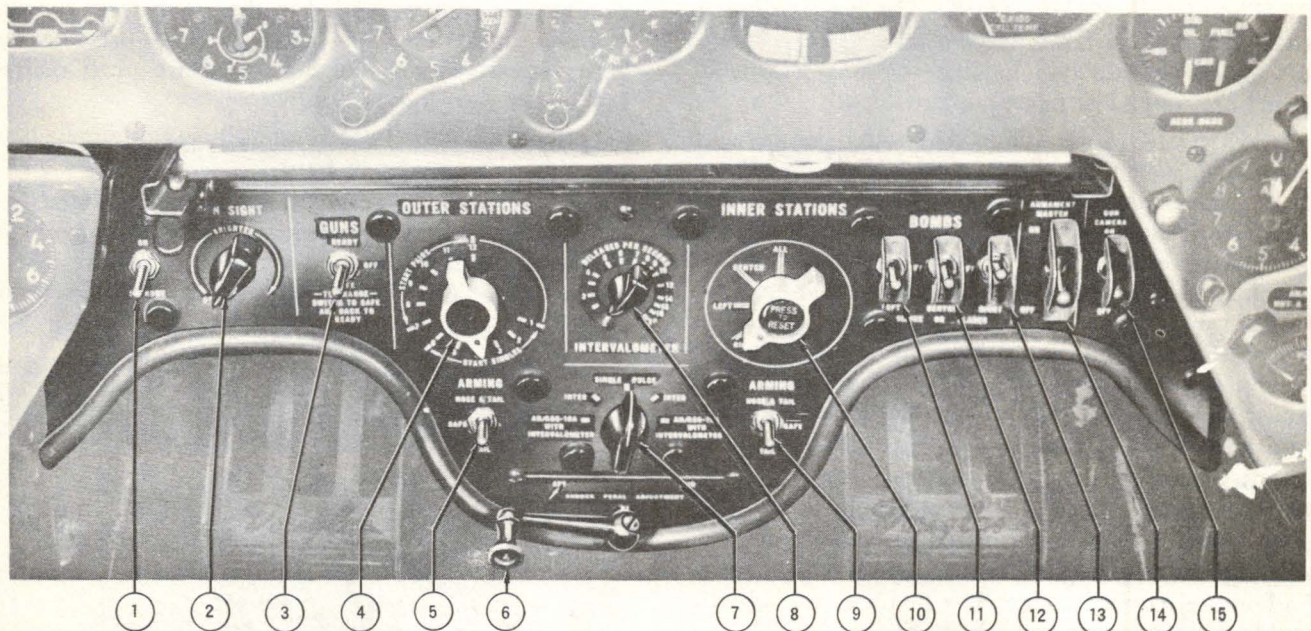

- | | |
|-----------------------------------|-------------------------------|
| 1. Gun Sight Switch | 9. Bomb Arming Switch |
| 2. Gun Sight Rheostat | 10. Bomb Selector Switch |
| 3. Gun Charging Switch | 11. Left Bomb Safety Switch |
| 4. Rocket Selector Switch | 12. Center Bomb Safety Switch |
| 5. Rocket Arming Switch | 13. Right Bomb Safety Switch |
| 6. Rudder Pedal Adjustment Crank | 14. Armament Master Switch |
| 7. Station Selector Switch | 15. Gun Camera Switch |
| 8. Intervalometer Selector Switch | |

Figure 4-1. Armament Control Panel

e. If light burns out or is inoperative, move gun sight switch to "STAND-BY" position.

f. The sight elevation may be adjusted in flight by moving the selector switch on the control box to "MANUAL" and rotating the dial to the desired setting. When the selector switch is placed in the "GUNS" position, the sight line will return to the normal (bore-sighted) position.

4-11. TO CHARGE THE GUNS. The wing guns may be charged by moving the arming switch from "OFF" to "SAFE" and then back to "READY."

4-12. TO FIRE THE GUNS.

- a. Armament master switch—"ON."
- b. Turn on gun sight.
- c. Charge guns.
- d. Squeeze trigger.

4-13. TO OPERATE THE GUN CAMERA. The gun camera is normally in operation automatically whenever the guns are fired or bombs are released. However, the camera may be operated manually by closing the camera control switch located on the armament control panel. (See figure 4-1, reference 15.)

4-14. BOMBING AND TORPEDO EQUIPMENT.

4-15. DESCRIPTION. One fuselage bomb rack and two wing racks are provided. All bombing operations are controlled by the pilot.

4-16. FUSELAGE BOMB RACK. The fuselage bomb rack is provided with a bomb ejector and has a maximum capacity of a 2000-lb. bomb or a Mk 13-3 torpedo. Manual and electrical release is provided.

4-17. WING BOMB RACKS. The wing bomb racks have a maximum capacity of one 2000-lb. bomb or Mk. 13-3 torpedo. (The operation of the landing flap is restricted when carrying a torpedo at the wing station.) Each wing bomb rack is also designed to carry a smoke tank, practice bomb rack, parachute flare container, fire bomb, 11.75 inch aircraft rocket or a droppable fuel tank. Provisions are also made for carrying radar equipment on the left-hand rack only. Manual and electrical release is provided for the wing bomb racks.

4-18. BOMB EJECTOR. The bomb ejector provided with the fuselage bomb rack is designed to displace the bomb away from the airplane sufficiently to clear the propeller in steep dives and operates by means of a bomb ejector cartridge. The bomb ejector circuit should be tested prior to each flight.

4-19. BOMBING AND TORPEDO CONTROLS.

4-20. BOMB SELECTOR SWITCH. This switch (figure 4-1, reference 10) located on the armament control panel will select bombs from the applicable rack when placed in the following positions:

- a. "RIGHT"—(Wing bomb rack only).
- b. "CENTER"—(Fuselage rack only).
- c. "LEFT"—(Wing bomb rack only).
- d. "ALL"—(All bombs salvo).

4-21. BOMB ARMING SWITCH (Inner stations). This switch (figure 4-1, reference 9) located on the armament control panel functions in any of the following positions.

- a. "NOSE & TAIL"—(Bomb drops armed at "NOSE & TAIL").
- b. "TAIL"—(Bomb drops armed at "TAIL" only).
- c. "SAFE"—(Bomb drops "SAFE").

4-22. BOMB SAFETY SWITCHES. Each of these three safety switches (figure 4-1, references 11, 12 and 13), located on the armament control panel, must be individually thrown to its respective position before a bomb may be released. The positions are "LEFT," "CENTER," "RIGHT" and "OFF."

4-23. INTERVALOMETER SELECTOR SWITCH. This selector switch (figure 4-1, reference 8), located on the armament control panel will determine the number of bombs per second or rocket releases per second singly or in pairs.

4-24. STATION SELECTOR SWITCH. This selector switch (figure 4-1, reference 7), located on the armament control panel, has the following positions:

- a. "SINGLE PULSE"—The bomb release button on the control stick must be pressed for each selected bomb release.
- b. "INTER"—("Inner stations"). When in this position any equipment carried in the bomb racks may be released singly or all racks salvoed by pressing the bomb release button and holding down until desired bombs, etc., are released.
- c. "INTER"—("Outer stations"). Permits rockets to be released singly or in pairs.
- d. "AN/ASG-10A" positions—Permits the AN/ASG-10A electronic equipment to be used in conjunction with the "INNER STATIONS" (Bomb selector switch) and "OUTER STATIONS" (Rocket selector switch).

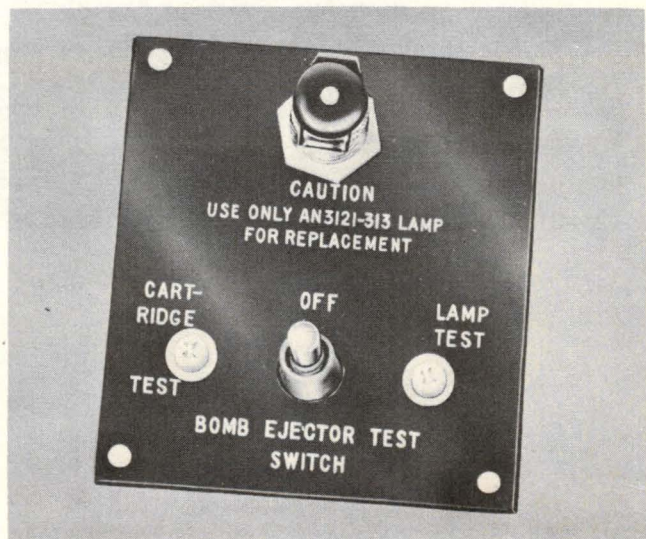

Figure 4-2. Bomb Ejector Test Box

4-25. BOMB EJECTOR TEST SWITCH. This switch (figure 4-2), located in the left-hand wheel well provides a means of checking the bomb ejector circuit.

4-26. OPERATION OF BOMBING AND TORPEDO EQUIPMENT.

4-27. TESTING BOMB EJECTOR SYSTEM. Prior to each flight, the bomb ejector circuit should be checked as follows:

- a. Battery switch—"ON."
- b. Center bomb safety switch—"RELEASE."
- c. Bomb ejector test switch—"CARTRIDGE."
- d. If test lamp lights, circuit is complete. If not, proceeds as follows:
 - e. Bomb ejector test switch—"LAMP."
 - f. If the test lamp lights, the cartridge circuit is open and should be checked. If it does not, the lamp is probably defective and should be replaced. In either case, the check should be repeated.

4-28. TO RELEASE BOMBS ELECTRICALLY.

- a. Armament master switch—"ON."
- b. Bomb safety switch—Set to "BOMBS" for bombs to be released.
- c. Bomb selector switch—Select bombs as desired.

Note

With all three safety switches set to "RELEASE," the bomb selector switch will release all three bombs in the following sequence: right, left, and center, unless set to "ALL" to salvo all three bombs.

- d. Bomb arming switch—Set as desired.
- e. Station selector switch—"INNER STATIONS."
- g. Set the intervalometer selector switch to the desired "RELEASES PER SECOND."
- h. Press the bomb release button and hold until all desired bombs are released.

4-29. TO RELEASE BOMBS MANUALLY. Refer to paragraph 3-37.

4-30. TO RELEASE TORPEDOES. Torpedoes are released in the same manner as the bombs (see paragraph 4-28 preceding). No provisions are installed for depth setting from the cockpit.

4-31. TO OPERATE SMOKE TANKS.

- a. Armament Master switch—"ON."
- b. Set either or both wing bomb safety switches to "SMOKE."
- c. Set the bomb selector switch to "LEFT," "RIGHT," or "ALL" (to release smoke from both tanks).

Note

If a bomb is being carried on the fuselage bomb rack, check to see that the center bomb safety switch is "OFF."

- d. Press the bomb release button to release smoke.
- e. After the smoke tanks are empty, the tanks may be dropped in the same manner as releasing a bomb.

4-32. TO RELEASE OTHER EQUIPMENT CARRIED ON BOMB RACKS. Other equipment carried on the bomb rack, such as mines, 11.75 inch rockets, flares, etc., is released in the same manner as bombs and torpedoes. (See paragraph 4-28.)

4-33. ROCKET EQUIPMENT.

4-34. DESCRIPTION. Provisions are made for carrying 12 five-inch HVA rockets, six under each wing panel.

4-35. ROCKET LAUNCHERS. Mark 9 rocket launchers, designed to carry 5 inch HVA rockets, are installed. The rockets are armed and fired electrically by the pilot.

4-36. The Mk. 2 station selector provides for firing rockets singly and in pairs. The selector jumps one position each time the rocket release button is pressed.

4-37. ROCKET CONTROLS.

4-38. ROCKET SELECTOR SWITCH. Lower left-hand side of armament control panel (figure 4-1, reference 4).

4-39. ROCKET ARMING SWITCH (outer stations). Above rocket selector switch (figure 4-1, reference 5).

4-40. OPERATION OF ROCKET EQUIPMENT.

4-41. TO RELEASE ROCKETS.

- a. Armament Master switch—"ON."
- b. Rocket selector switch—As desired.
- c. Rocket arming switch—As desired.
- d. Station selector switch—"OUTER STATIONS."
- e. Turn on gun sight.
- f. Set the intervalometer selector switch to the desired "RELEASES PER SECOND."

Note

The setting of the interval selector switch indicates the number of releases per second singly or in pairs when the intervalometer is used.



The Mk. 2 Station Selector has no provision for salvo.

4-42. OXYGEN EQUIPMENT.

4-43. GENERAL. A diluter-demand oxygen system is provided. The oxygen cylinder is located underneath the right-hand floor of the cockpit and an OXYGEN SHUTOFF valve (figure 1-3, reference 3) remotely controlling the cylinder valve protrudes through the left-hand console panel. The oxygen cylinder has a capacity of 295 cubic inches. The oxygen cylinder refill valve is located just below the enclosure on the right-hand side of the cockpit. A diluter-demand regulator (figure 1-3, reference 1) for the pilot is temporarily located in the cockpit to the left and aft of the pilot's seat. A console type regulator panel, to the left of the

pilot, will be installed as a service change at a later date. The diluter-demand regulator is similar in operation to the demand regulator except that an air admission valve, which allows air from the outside to enter the breathing system is incorporated. The amount of air admitted is dependent upon the altitude up to approximately 30,000 feet, beyond which 100 percent oxygen is automatically delivered. A blinker flow indicator and the oxygen system pressure gage is provided on the left-hand console panel forward of the engine controls.

4-44. **PREFLIGHT CHECK.** The following items should be checked at regular intervals when the airplane is on the ground, and whenever possible before flights in which oxygen is likely to be used, to assure proper functioning of the oxygen system:

- a. Check to see that the regulator emergency valve is closed.
- b. Open the cylinder valve. Allow at least ten seconds for pressure in the line to equalize. Pressure gage should read 1800 ± 50 psi if the cylinder is fully charged.
- c. Close the cylinder valve. After a few minutes observe the pressure gage and simultaneously open the cylinder valve. If the gage pointer *jumps*, leakage is indicated, and the system should be subjected to the "Ground Crew Test" (see Technical Note No. 94-45) prior to use.
- d. Put on the mask. Check the mask fit by placing the thumb over the disconnect at the end of the mask tube and inhale lightly. If there is no leakage, the mask should adhere tightly to the face and a definite resistance to inhalation should be encountered. If the mask leaks, tighten the mask suspension straps and/or adjust the nose wire. **DO NOT USE A MASK THAT LEAKS.**
- e. Fully engage the mating portions of the disconnect coupling to connect the mask to the oxygen system breathing tube.
- f. Breathe several times with the regulator air valve in both "NORMAL OXYGEN" and "100 PERCENT OXYGEN" positions to check regulator operation and observe the flow indicator for "blink," verifying the positive flow of oxygen.

4-45. **OPERATING INSTRUCTIONS.** The following procedures should be followed when oxygen is used during flight:

- a. Check to see that the cylinder valve is open. The pressure gage should read 1800 ± 50 psi if the cylinder is fully charged.
- b. Set the air valve to "NORMAL OXYGEN" for all normal flight conditions.
- c. Put the mask on. Fully engage the mating portions of the disconnect couplings to connect the mask to the oxygen system breathing tube. Attach the clip to the parachute harness (or clothing) sufficiently high on the chest to permit free movement of the breathing tube.

Note

In order that the breathing tube does not interfere with body movement, it is necessary to sew a loop on the pilot's flight suit, so that in a sitting position it will retain the lower end of the disconnect.

- d. To check the mask fit, squeeze the mask tube and inhale lightly. If there is no leakage, the mask should adhere tightly to the face and a definite resistance to inhalation should be encountered. If the mask leaks, tighten the mask suspension straps.



Never obstruct free flow of oxygen from the regulator while the emergency valve is open.

4-46. The following should be checked frequently while on oxygen:

- a. Cylinder pressure gage for oxygen supply.
- b. Oxygen flow indicator for flow of oxygen through regulator.
- c. Mask fit for leak tightness.
- d. In event of loss of radio communication, check the personnel gear receptacle to see that the connector is plugged in.

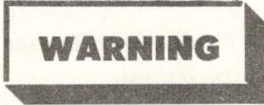

Oxygen supply is also dependent on this disconnect.

4-47. **EMERGENCY CONDITIONS.**

- a. Should symptoms occur suggestive of the onset of anoxia, or the regulator becomes inoperative, immediately turn on the emergency valve and descend below 10,000 feet.
- b. Whenever excessive carbon monoxide or other noxious or irritating gas is present or suspected, regardless of altitude, the air valve should be turned to "OFF" or "100 PERCENT OXYGEN," and undiluted oxygen used until the danger is passed or the flight is completed.
- c. Do not exhaust supply cylinder below 300 psi except in an emergency.
- d. The following table may be used to determine the amount of oxygen available at various altitudes.

ALTITUDE (FEET)	DURATION (HOURS)	
	AIR VALVE "ON" (Normal Flow)	AIR VALVE "OFF" (100% Oxygen)
10,000	5.2	0.65
15,000	4.9	0.90
20,000	4.0	1.10
25,000	2.4	1.30
30,000	1.8	1.80

4-48. Should brief removal of the mask from the face be necessary at high altitude, the following procedure should be used:

- a. Take three or four deep breaths of 100 per cent oxygen (air valve set to "OFF" or "100 PERCENT OXYGEN").
- b. Hold breath and remove mask from face.
- c. As soon as practicable, replace mask to face and take three or four deep breaths of 100 percent oxygen.
- d. Reset the air valve lever to the normal operating position.

Note

The emergency valve should be closed at all times except in an emergency, and then it should be opened slowly to minimum flow required.

4-49. RADIO, COMMUNICATION, NAVIGATION AND SPECIAL ELECTRONIC EQUIPMENT.

4-50. GENERAL. The following equipment is installed in AD-2 Airplanes:

DESIGNATION	TYPE	RANGE (Approx.)
AN/ARC-1	VHF equipment	Horizon (dependent on altitude)
AN/ARR-2A	Navigation receiver	Horizon (dependent on altitude)
AN/APX-2	IFF equipment	Horizon (dependent on altitude)
AN/ARC-5	Range receiver	50 miles
AN/APN-1	Radio altimeter	Zero to 400 ft. and zero to 4000 ft.
AN/APS-4	Radar equipment	Indicated on equipment but restricted by altitude.
AN/ASG-10A	Electronic bombing equipment	Not applicable

WARNING

The above horizontal ranges are approximate and are dependent on existing conditions, ground equipment, etc.

4-51. All radio equipment is located in the radio compartment in the after end of the fuselage except the AN/APX-2 equipment which is located in the forward equipment compartment. All radio operations are controlled by the pilot.

4-52. DESCRIPTION.

4-53. COMMUNICATIONS EQUIPMENT. The communications radio equipment includes the AN/ARC-1, and AN/ARC-5 radios. The AN/ARC-1 equipment provides very high frequency (VHF) radio telephone communication in the frequency range of 100 to 156 megacycles. The AN/ARC-5 ferry equipment provides low-frequency (LF) receiving in the frequency range of 190 to 550 kilocycles.

4-54. NAVIGATION EQUIPMENT. AN AN/ARR-2A navigation receiver is provided.

4-55. SPECIAL ELECTRONIC EQUIPMENT. The airplane is equipped with an AN/APX-2 IFF set, AN/APS-4 radar set, AN/APN-1 radio altimeter, and AN/ASG-10A bombing equipment.

4-56. RADIO CONTROLS. Console controls for all radio equipment are installed on the right-hand console panel (figure 1-3, sheet 2 of 2) except for the AN/APS-4 Radar equipment (figure 1-3, reference 11) which is located on the left-hand console panel. The master switch and volume control for all radio equipment is on the right-hand radio console panel.

4-57. OPERATION OF RADIO, COMMUNICATIONS AND NAVIGATION EQUIPMENT.

4-58. ON ENTERING THE COCKPIT.

- a. Connect the microphone and headset cord to the personnel gear receptacle (figure 1-3, reference 20.) As a secondary provision, it is possible to connect the microphone and headset cord to the CX 922/AR coiled set cord on the right-hand console panel.

WARNING

Make certain that the plugs are fully engaged.

- b. After the engine is running and the generator is charging properly (1500 rpm or over) or with an external 24 volt power source connected, turn the radio master switch "ON" to furnish power to all radios. Adjust the volume control as necessary. Allow approximately one minute for the equipment to warm up.

4-59. OPERATING INDIVIDUAL RECEIVERS.

4-60. AN/ARC-1 (VHF) RECEIVER. Advance the radio volume control on the master unit for normal reception. Turn the guard-main switch on the "VHF" control unit, to the "BOTH" position and rotate the channel selector switch to the desired channel. At the conclusion of reception reduce the volume as necessary by means of the radio volume control on the master unit.

4-61. AN/ARC-5 (LF) RANGE RECEIVER. Turn the tuning knob on the "RECVR" unit to the desired frequency and adjust the sensitivity control for normal operation. THIS CONTROL SHOULD BE SET FOR THE MINIMUM REQUIRED FOR RECEPTION TO AVOID INCORRECT COURSE INDICATIONS. Adjust the master unit volume control as necessary. When operation is concluded turn the sensitivity control to a minimum.

4-62. AN/ARR-2A NAVIGATION RECEIVER. Turn the channel selector knob on the "NAVIG" unit to the assigned channel number. Turn the "NAV.-VOICE" switch to "NAV." Adjust the sensitivity control knob to produce a usable weak signal or, if the desired signal cannot be heard, to a fairly strong background hiss. Adjust the master unit volume control

as necessary. If a signal is present, adjust the pitch control knob to produce a pleasing, audible tone. Readjust the sensitivity control knob to keep the signal rather weak. When the operation is completed turn the sensitivity control to its lowest output.

4-63. SIMULTANEOUS RECEPTION. With the navigation receiver in operation as described, adjust the controls on the "RECVR" and "NAVIG" unit. The "GUARD-BOTH-MAIN T/R" switch on the "VHF" units should be in the "BOTH" position so that the guard channel and the main T/R channel will be monitored simultaneously. The outputs of all three receivers are now being fed simultaneously into the headphones.

4-64. TRANSMISSION.

Note

THESE INSTRUCTIONS ARE SUBJECT TO LOCAL LIMITATIONS REGARDING RADIO SILENCE.

4-65. AN/ARC-1 (VHF) TRANSMITTER. Rotate the guard-main switch on the "VHF" unit to "MAIN T/R" and rotate the channel selector switch for transmission on any one of the nine channels. Commence transmission by pressing the throttle switch.

4-66. PRECAUTIONS. The pilot should acquaint himself with all pre-set controls and equipment and not try to re-adjust them in flight.

4-67. PILOT'S CHECK-OFF LIST.

4-68. BEFORE TAKE-OFF.

a. Connect personnel gear receptacle connector.

b. Radio master switch "ON" after generator is charging (1500 rpm or above) or external power source is connected.

c. Allow approximately one minute for equipment to warm up.

d. Diminish all audio outputs.

4-69. AFTER LANDING. Before leaving the airplane, all radio equipment should be secured by turning the radio master switch "OFF."

4-70. OPERATION OF SPECIAL ELECTRONIC EQUIPMENT.

4-71. PREFLIGHT CHECK OF EQUIPMENT. Operation of the following equipment requires that the engine generator is operating properly (1500 rpm or above) or an external power supply is provided. The AN/ASG-10A electronic bombing equipment should be tested before take-off and adjustments made for the type of missile to be released. This should be done by the ground crew in accordance with procedures given in "The Operators Manual for Bomb Director Mk. 1 Mod. 2, AN/ASG-10A" CO NAVAER 16-5S-524. All other equipment should be checked as noted in the following paragraphs.

4-72. POWER SOURCE. See paragraph 4-58b preceding. The procedure is standard for all equipment.

4-73. STARTING AND STOPPING EQUIPMENT.

4-74. AN/APX-2 IFF EQUIPMENT.

4-75. TO START EQUIPMENT. Rotate the master control switch, on the IFF control unit, clockwise away from the "OFF" position and set it in the desired operating position.

4-76. TO STOP EQUIPMENT. Rotate the master control switch, on the IFF control unit, to the extreme counterclockwise position marked "OFF."

4-77. CHECK-OFF LIST.

a. SELECTOR SWITCH. Move to a designated position, which is usually position "1."

b. FOR G-BAND OPERATION. Throw the G-Band switch, on the IFF console unit, to the "CONT" position or flip it to the "TMPRY" position.

c. FOR INT OPERATION. Throw the "INT" switch on the IFF console control unit, to the "INT" position or hold it momentarily in the "TMPRY" position.

d. FOR ROO OPERATION. Rotate the master control switch, on the IFF console control unit, to the "ROOSTER" position. (Only by specific direction of the Commanding Officer and only if a specified ROO adjustment has been made inside the transmitter-receiver unit by a maintenance crew.)

e. FOR DISTRESS OPERATION. Push the guard latch, on the IFF console control unit, to the right (tilting it up) and rotate the master control switch to the "EMERGENCY" (extreme clockwise) position. See paragraph 3-35.

f. TO DESTROY THE TRANSMITTER-RECEIVER UNIT. (See paragraph 3-35.)

4-78. AN/APS-4 RADAR EQUIPMENT.

4-79. INITIAL CHECK OF SETTINGS.

a. "RADAR-BEACON" switch—"RADAR."

b. "SEARCH-INTERCEPT" switch—"SEARCH."

c. "RANGE" switch—Second position from the left.

d. "TILT" switch—Zero tilt position.

e. "GAIN" switch—Full counterclockwise.

f. "OFF-HOLD 1 MIN-RUN" switch—"OFF."

g. "INTENSITY" knob—Full counterclockwise.

h. "TUNE" knob—Center.

4-80. TO START EQUIPMENT. Throw the "OFF-HOLD 1 MIN-RUN" switch to the "HOLD 1 MIN" position. After an interval of at least one minute (two to three minutes in extreme cold), throw the switch to the RUN position.

4-81. TO STOP EQUIPMENT.

a. "OFF-HOLD 1 MIN-RUN" switch to "OFF."

b. INTENSITY control—Full counterclockwise.

c. "GAIN" control—Full counterclockwise.

4-82. CHECK-OFF LIST.

4-83. IF SURFACE TARGETS ARE SOUGHT.

- a. "OFF-HOLD 1 MIN-RUN" switch—"HOLD 1 MIN."
- b. "RADAR-BEACON" switch—"RADAR."
- c. "SEARCH-INTERCEPT" switch—"SEARCH."
- d. "RANGE" switch—Second position from the left.
- e. "TILT" control—One position to the left of the zero tilt position.
- f. "GAIN" control—45° to the left of vertical.
- g. "TUNE" control—Center.
- h. One minute after turning the "OFF-HOLD 1 MIN-RUN" switch to "HOLD 1 MIN," (two or three minutes in extreme cold), turn it to "RUN."
- i. Turn the INTENSITY control to illuminate moderately the indicator screen.
- j. Adjust "TUNE" and "GAIN" controls.

4-84. IF AIR TARGETS ARE SOUGHT.

- a. "OFF-HOLD 1 MIN-RUN" switch to "HOLD 1 MIN."
- b. "RADAR-BEACON" switch—"RADAR."
- c. "SEARCH-INTERCEPT" switch—"INTERCEPT."
- d. "RANGE" switch—First position from the left.
- e. "TILT" control—Zero tilt position.
- f. "GAIN" control—45° to the left of vertical.
- g. "TUNE" control—Center.
- h. One minute after turning the "OFF-HOLD 1 MIN-RUN" switch to "HOLD 1 MIN" (two or three minutes in extreme cold), turn it to "RUN."
- i. Turn the INTENSITY control to a position to illuminate moderately the indicator screen.
- j. Adjust "TUNE" and "GAIN" control.
- k. Operate the "TILT" control for optimum results.

4-85. IF BEACON HOMING IS DESIRED.

- a. "OFF-HOLD 1 MIN-RUN" switch to "HOLD 1 MIN."
- b. "RADAR-BEACON" switch—"BEACON."
- c. "SEARCH-INTERCEPT" switch—"SEARCH."
- d. "RANGE" switch—Extreme right position or the next position to the left.
- e. "TILT" control—zero tilt position.
- f. "GAIN" control—45° to the left of vertical.
- g. "TUNE" control—center.
- h. One minute after turning the "OFF-HOLD 1 MIN-RUN" switch to "HOLD 1 MIN" (two or three minutes in extreme cold), turn it to "RUN."
- i. Turn the INTENSITY control to illuminate moderately the indicator screen.
- j. Adjust "TUNE" and "GAIN" control.

4-86. AN/APN-1 RADIO ALTIMETER SET.

4-87. TO START EQUIPMENT. To commence operation turn the power switch located on the radio altitude indicator to "ON."

4-88. TO STOP EQUIPMENT. Turn the power switch counterclockwise.

4-89. CHECK-OFF LIST.

- a. Allow one minute for the tubes to heat and observe that the indicator has moved from its sub-zero stop position to some other position indicating that the equipment is energized.



When the airplane is resting on the ground, the indicator pointer may not indicate zero altitude.

b. Set range switch located on the radio altitude indicator to the desired altitude range.

c. Set limit switch located on the AN/APN-1 console panel for the altitude at which the limit indicator light, which is installed adjacent to the indicator, will operate.

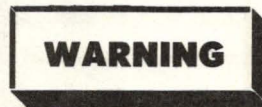

The HIGH RANGE of the altimeter must never be used when flying at altitudes within the LOW RANGE or when landing.

4-90. AN/ASG-10A BOMBING EQUIPMENT.

4-91. GENERAL. AN/ASG-10A equipment is a device that determines the time at which a bomb, rocket, or torpedo is to be released from a plane as it pulls out of a dive. The dive must be aimed at the target. The factors from which the computer works out a solution are: (1) altitude, (2) airspeed, (3) dive-angle, (4) pull-out acceleration, and (5) ballistic coefficient of the missile.

4-92. PREFLIGHT CHECK.

4-93. Adjustments to be made before take-off when bombs or torpedoes are to be released.

a. The Bomb M.P.I. Adjustment Control located on the computer is set to compensate for the ballistic coefficient of the bomb used.

b. The Stick Length Offset Control located on the Control Box is set to "ZERO" if a single bomb or a salvo is to be released. If a stick of bombs is to be released the Stick Length Offset Control is rotated to the left so that the first bomb will strike short by one-half the stick length. If a Torpedo is to be released, the Control knob is set at "TORP."

c. The Transfer Switch, located on the Control Box, is set to "UNCAGE."

4-94. Adjustments to be made before take-off when rockets are to be released.

a. The Temperature and Lanyard Control on the Computer is set from tabular data.

b. The Rocket Calibration—Course and the Rocket Calibration—Fine Controls, both on the Computer, are set from tabular data.

c. The Transfer Switch on the Control Box is set to the "Rocket" position.

d. The Gyro Switch on the Control Box is set to "U cage."

e. The Stick Length Offset Control Knob is set to "Zero."

4-95. TO START EQUIPMENT. Turn the Power Switch on the Control Box to "ON" 15 minutes before the equipment is to be used to allow the tubes to stabilize.

4-96. TO STOP EQUIPMENT. Turn the Power Switch on the Control Box to "OFF" position.

4-97. CHECK-OFF LIST.

a. Set Altimeter to read "ZERO" at the altitude of the target.

b. Set the Air Speed dial on the Computer at the most probable speed of attack.

c. Cage and uncage the gyro in level flight before entering the dive, to make certain that it has not tumbled.

4-98. Making the Bombing Run, when Bombs, Rockets, or Torpedoes are to be released.

a. The target is approached and the dive made toward it with offset allowance for wind or target motion using the fixed gunsight reticule for reference. The dive is initiated several thousand feet above the altitude at

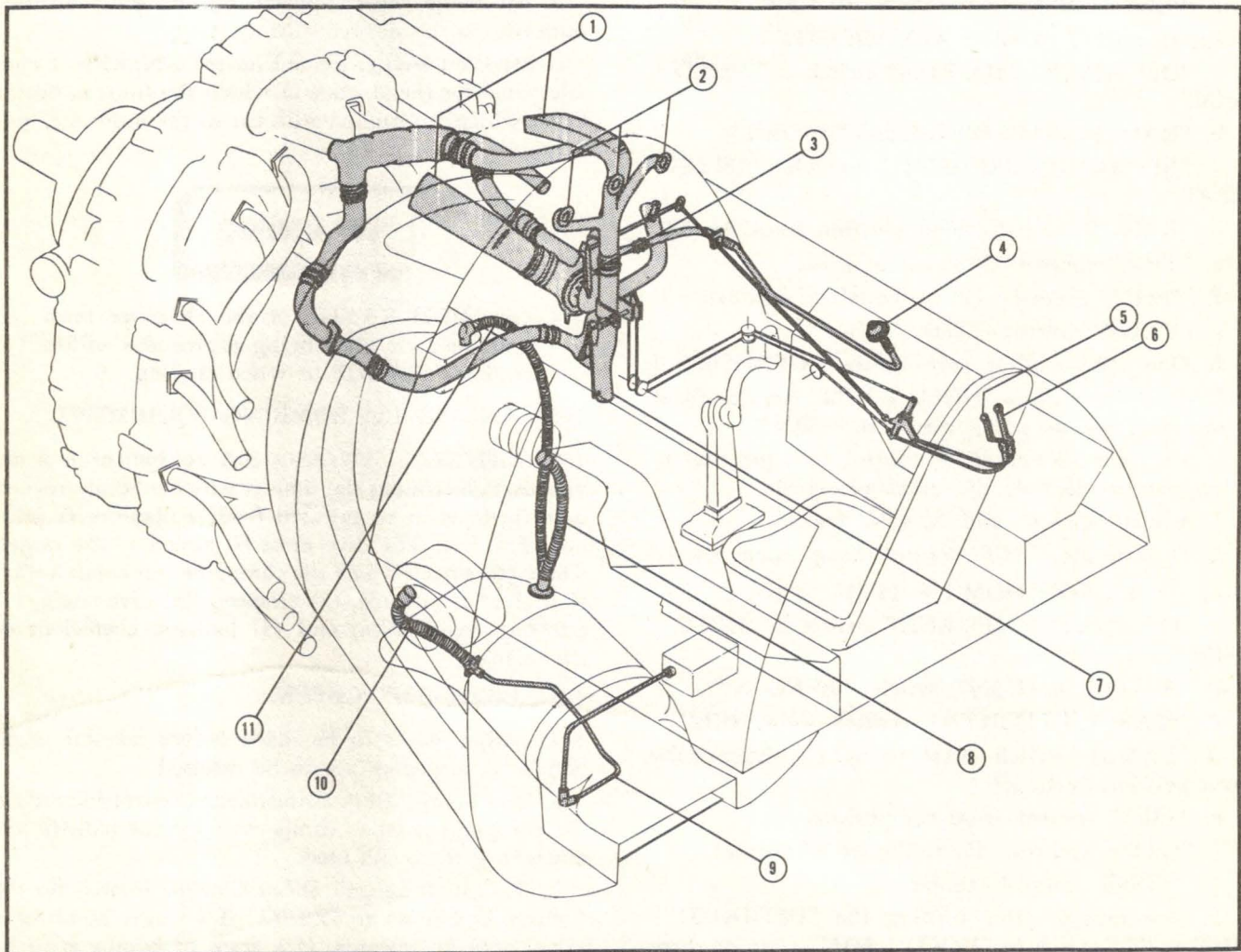

- | | |
|------------------------------|---|
| 1. Air Intake Ducts | 7. Cockpit Heating and Ventilating Duct |
| 2. Windshield Defogger Ducts | 8. Engine Generator Cooling Duct |
| 3. Ventilating Air Intake | 9. Voltage Regulator Cooling Duct |
| 4. Ventilating Air Outlet | 10. Hydraulic Reservoir Cooling Duct |
| 5. Ventilating Air Control | 11. Engine Magneto Cooling Duct |
| 6. Heating Air Control | |

Figure 4-3. Heat and Vent System Diagram

which the Bomb Release switch (located on the stick) is closed and may be made at any angle between 15° and 60°. The Indicated Air Speed must be greater than 250 knots before the Bomb Release switch is pressed, and constant velocity should be attained as nearly as possible.

b. When the point of aim and the air speed are satisfactorily established, the Bomb Release switch is pressed and held. The dive is continued toward the target until the Indicator Lamp lights.

c. After the Indicator Lamp is lighted the pull-out is initiated sharply, in such a manner that the target disappears in a path parallel to the vertical line of the sight reticule. Bombs, rockets or torpedoes are automatically released during the pull-out at which time the Indicator Lamp goes out and the Bomb Release Switch may be released.

d. If the pilot decides not to release he may let up on the Bomb Release Switch at any time before the projectile is released and all circuits will be cleared and ready for another run.

4-99. For the case of an aircraft carrying a mixed load the correct adjustments for both types of missiles are made by the ground crews before take-off. The pilot can then select either bombs or rockets by:

a. Setting the Stick Length Offset Control Knob on the Control Box at the correct place for the missile;

b. Setting the Transfer Switch on the Control Box to the desired position. The procedure then follows as above. See paragraph 4-97.

4-100. WINDSHIELD DEFOGGER AND FOOT WARMER SYSTEM.

4-101. GENERAL. Air is taken in through an intake duct on top of the fuselage just forward of the cockpit and circulated through a heater muff around the exhaust stacks and then to the distributor valve. The distributor valve control (figure 1-3, reference 97) is located to the right of the pilot and provides for three positions: "OFF," "WINDSHIELD & CABIN" and "ALL TO WINDSHIELD." Intermediate heat can be obtained by placing the control in any desired intermediate position.

4-102. VENTILATION SYSTEM.

4-103. GENERAL. Air taken in from the intake duct is routed directly to a diffuser outlet at the firewall. The amount of air flow is controlled by the "VENTILATOR" lever (figure 1-3, reference 98) directly to the right of the pilot's seat. An additional air outlet (eyeball) is provided on the right-hand console panel, which may be adjusted to direct the flow of air over the upper portion of the pilot's body. (See figure 1-3, reference 73.)

4-104. WINDSHIELD DEGREASING SYSTEM.

4-105. GENERAL. A windshield degreasing system is provided for improved visibility. A momentary contact control switch is located on the right-hand side of the instrument panel.

4-106. LIGHTING EQUIPMENT.

4-107. GENERAL. An "INTERIOR LIGHTS" control switch and rheostat (figure 1-3, reference 93) and an "EXTERIOR LIGHTS" console panel (figure 1-3, reference 95) are located directly to the right of the pilot's seat.

4-108. The "EXTERIOR LIGHTS" console panel switches function as follows:

Five "ON" "OFF" exterior light selector switches. "BRILLIANCE" switch selects—"DIM," "MED," "BRT.") positions.

"MASTER" switch selects—"OFF."

"CODE" (Applies to upper and lower fuselage lights only. Wing tip and tail lights will burn steadily if their control switches are "ON.")

"FLASH" (Applies to wing and tail lights only. If fuselage light switch is turned "ON," the fuselage lights will burn steadily.)

"STDY" (All selector switches will burn steadily when in the "ON" position.)

"CODE" switch—Upper and lower fuselage lights only, signal letter selected, when "MASTER" switch is in "CODE" position. "KEYING" switch—Manually codes fuselage lights at any time, regardless of position of "MASTER" switch. (Assuming the fuselage light toggle switch is in the "OFF" position.)

RESTRICTED
AN 01-40ALA-1

APPENDIX I

OPERATING CHARTS, TABLES, CURVES AND DIAGRAMS

A-1. FLIGHT PLANNING.

A-2. FLIGHT OPERATION CHARTS. The following pages contain charts to be used as a guide to the planning of operations. Charts provided are a Take-off, Climb, and Landing Chart and a set of Flight Operation Instruction charts which covers the probable gross weight range for the stated configuration.

A-3. GENERAL.

a. The methods of computing flight time, fuel requirements, and range vary, depending on the type of operation and mission planned. These instructions cannot possibly cover all the types of possible operation, but they do cover the more common types likely to be encountered, as for example, simple continuous flight at fairly constant power or a bombing mission with allowances for combat operation.

b. The Flight Operation Instruction Charts have been set up so that ranges in Column I are for Maximum Continuous (Normal Rated) Operation, which gives the maximum airspeed possible with an indefinite time limit on the engine. Progressively greater range is obtained as one moves from Column I toward Column V with a corresponding decrease in airspeed.

c. Within the limits of the chart, airspeed is obtained at a sacrifice in range, and in a like manner, range is increased with a sacrifice in airspeed. It should be noted that the fuel required and the flying time for a given mission depend mainly on the airspeed desired. By selecting a higher altitude, a higher true airspeed is obtained, and the flight time is shortened. This will not affect the range, since all power settings listed within a column are set up to approximately the same air miles per pound of fuel at each altitude.

d. The approximate airspeed desired is determined by weighting the urgency of the mission against the range required.

A-4. USE OF THE CHARTS. The simplest type of mission to plan is one in which the flight is continuous at constant altitude, and the desired cruising power and airspeed are reasonably constant. This is known as a "single stage flight." An example of the use of the charts for this type of mission appears at the bottom of each Flight Operation Instruction Chart; however, the following general information may be of value.

a. Assuming the range to be flown is known, choose the altitude at which the flight is to be made. The main factors in the choice of altitude are weather conditions, oxygen requirements, and the approximate true airspeed desired.

b. Enter the Climb Data Chart (figure A-7) at the chosen altitude and the approximate gross weight of the airplane before take-off, and read the fuel used in climb to this operating altitude.

Note

Allowances have been made in the Climb Data Chart for warm-up and take-off as well as fuel used in climb.

c. Determine the fuel reserve desired and add this to the climb allowance. *No allowances have been made in the Flight Operation Instruction Charts for wind, navigational error, or other contingencies. No allowance has been made for combat or formation flight. The allowances to be made for each of these items will be dictated by local doctrine.*

d. Add allowances made in (b) and (c), and subtract this total allowance from the fuel available in the airplane before starting the engines. The result is the value to be used in entering the chart.

e. Select the appropriate Flight Operation Instruction Chart corresponding to the approximate gross weight of the airplane before take-off and to the external load items carried. Alternate external loadings, if applicable, are listed in the notes at the bottom of each chart.

f. Find the figure in the fuel column of the chart equal to (or just below) the amount of fuel determined in (d) to be available for flight.

g. Read horizontally to the right or left and select a range value equal to (or just above) the number of air miles (with no wind) to be flown.

h. Move vertically down the column, and opposite the chosen altitude, read the RPM, M.P., Mixture setting, and Blower setting. The airplane may be flown using values contained under operating data in any column to the right; however, this will result in the mission being accomplished at a sacrifice in airspeed but with an increase in fuel economy.

A-5. A little more complex, but very common, type of operation is one for which the airplane gross weight is considerably higher when cruising out than when cruising back. This is because of bombs dropped, empty drop tanks released, and the large weight of fuel consumed during cruise out on long missions. In such a problem, the following general comments may be helpful.

a. The appropriate Flight Operation Instruction Chart corresponding to the approximate gross weight and external load items for each phase of the mission (cruise out and cruise back) should be for that phase.

b. In making a fuel allowance for climb to cruise back, the value taken from the Climb Chart of the cruise back altitude may be decreased by 320 lb., the amount of the warm-up and take-off allowance.

c. Fuel used in climb from one altitude to another may be obtained by subtracting the "fuel used" entries in the Climb Chart for the two altitudes and at the approximate gross weight.

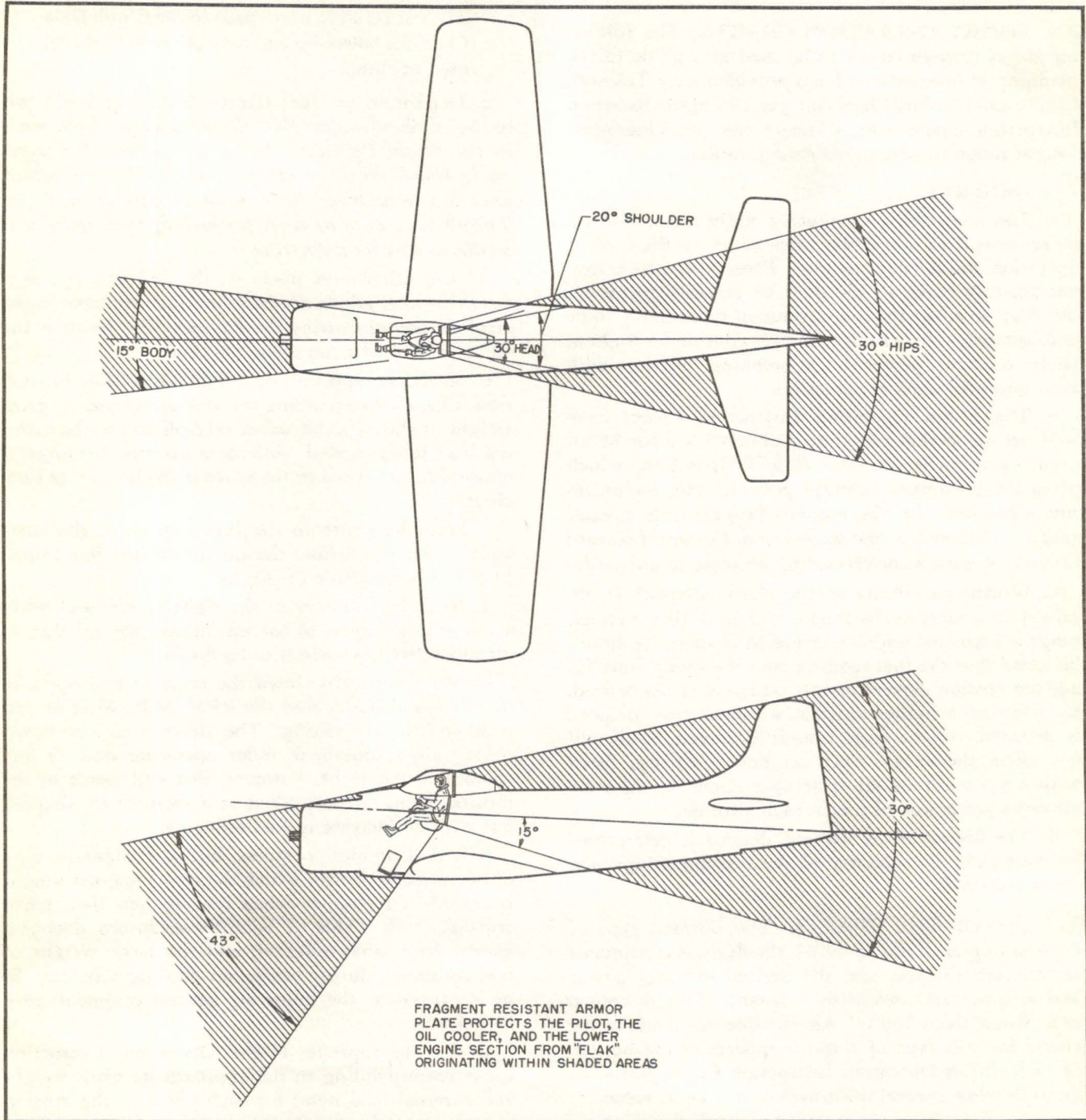

Figure A-1. Protection from Gunfire Diagram

<u>Flaps Down — Gear Down</u>				
I.A.S. (Knots)	<u>Power On</u>	Correction (Knots)	<u>Power Off</u>	Correction (Knots)
	70		Deduct	
80	Deduct	3	Add	1
90	Deduct	2	Add	0
100	Deduct	2	Add	0
110	Deduct	2	Add	0
120	Deduct	3	Add	0
130	Deduct	5	Add	1

<u>Flaps Up — Gear Up</u>				
I.A.S. (Knots)		Correction (Knots)		
		100	Add	
150	Add	2		
200	Add	3		
250	Add	4		
300	Add	4		
350	Add	5		
400	Add	6		

NOTE
These calibrations represent the airspeed position error and give the corrected indicated airspeeds for a given reading of the cockpit airspeed indicator assuming zero scale error for the instrument itself.

Figure A-2. Airspeed Installation Correction Table

STALLING SPEEDS
CALIBRATED (KNOTS)

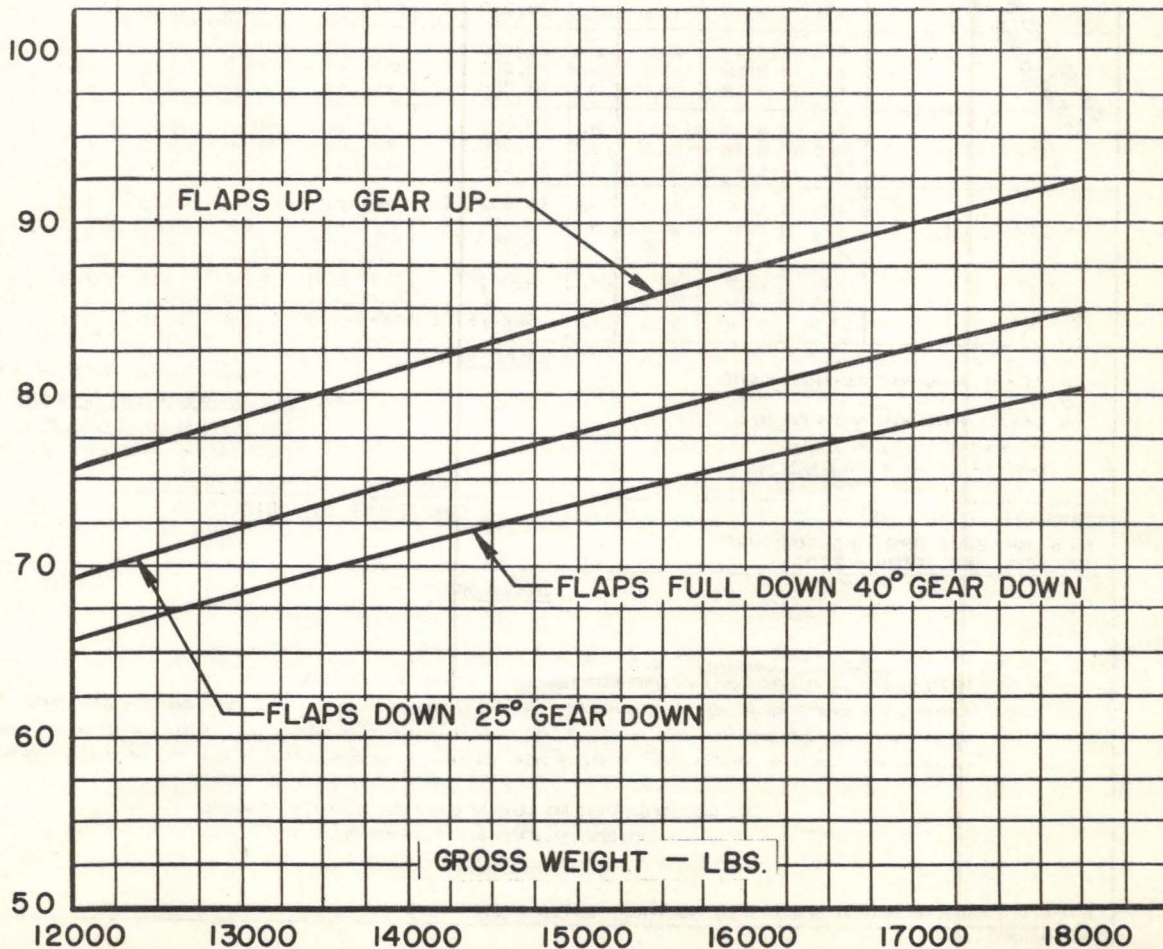

Figure A-3. Stalling Speed vs. Gross Weight Relationships

POWER PLANT CHART

AIRCRAFT MODEL
AD-2

PROPELLER
AERO PRODUCTS
A-642-G/M20B-162-O

ENGINE MODEL
R3350-26W
TWO SPEED

GAUGE READING	FUEL PRESS.	OIL PRESS. (REAR)	OIL PRESS. (FRONT)	OIL TEMP. °C	MAXIMUM PERMISSIBLE DIVING RPM: 3000 MINIMUM RECOMMENDED CRUISE RPM: 1400 OIL GRADE: 1120, SPEC AN-O-8 FUEL GRADE: 115/145, SPEC AN-F-33-1
DESIRED	20	70	35	80	
MAXIMUM	21	75	40	102	
MINIMUM IDLING	19	65	30	60 ⁽³⁾	

COMBAT POWER (COMBAT EMERGENCY)			MILITARY POWER (NON-COMBAT EMERGENCY)			OPERATING CONDITION			NORMAL RATED (MAXIMUM CONTINUOUS)			MAXIMUM CRUISE (NORMAL OPERATION)		
(2) MINUTES			(2) 30 MINUTES(4)			TIME LIMIT			UNLIMITED			UNLIMITED		
			260° C			MAX. CYL. HD. TEMP.			245° C			230° C		
			NORMAL			MIXTURE			NORMAL			NORMAL		
			2900 (LOW) 2600 (HIGH)			R. P. M.			2600			2300		
MANIF. PRESS.	SUPER-CHARGER	FUEL ⁽²⁾ Lb/MIN	MANIF. PRESS.	SUPER-CHARGER	FUEL ⁽²⁾ Lb/MIN	STD. TEMP. °C	PRESSURE ALTITUDE	STD. TEMP. °F	MANIF. PRESS.	SUPER-CHARGER	FUEL L&P.H. ⁽²⁾	MANIF. PRESS.	SUPER-CHARGER	FUEL L&P.H. ⁽²⁾
						-55.0	40,000 FT.	-67.0						
						-55.0	38,000 FT.	-67.0						
						-55.0	36,000 FT.	-67.0						
						-52.4	34,000 FT.	-62.3						
						-48.4	32,000 FT.	-55.1						
						-44.4	30,000 FT.	-48.0						
						-40.5	28,000 FT.	-40.9						
						-36.5	26,000 FT.	-33.7						
						-32.5	24,000 FT.	-26.5	F.T.	HIGH	1072	F.T.	HIGH	760
						-28.6	22,000 FT.	-19.4	F.T.	HIGH	1245	30.0	HIGH	837
						-24.6	20,000 FT.	-12.3	F.T.	HIGH	1432	30.0	HIGH	810
						-20.7	18,000 FT.	-5.2	F.T.	HIGH	1612	30.0	HIGH	795
						-16.7	16,000 FT.	2.0	F.T.	HIGH	1695 ⁽⁷⁾	F.T.	LOW	789
						-12.7	14,000 FT.	9.1	44.0	HIGH	1640	F.T.	LOW	981
						-8.8	12,000 FT.	16.2 ⁽⁶⁾	F.T.	LOW	1501	31.0	LOW	981
						-4.8	10,000 FT.	23.4	F.T.	LOW	1640	31.0	LOW	934
						-0.8	8,000 FT.	30.5	F.T.	LOW	1780	31.0	LOW	881
						3.1	6,000 FT.	37.6	45.0	LOW	1904	31.0	LOW	820
						7.1	4,000 FT.	44.7	45.0	LOW	1856	31.0	LOW	781
						11.0	2,000 FT.	51.8	45.0	LOW	1819	31.0	LOW	753
						15.0	SEA LEVEL	59.0	45.0	LOW	1780	31.0	LOW	729

GENERAL NOTES

(1) Lb/MIN: APPROXIMATE POUNDS PER MINUTE

(2) LB.P.H.: APPROXIMATE POUNDS PER HOUR
FT.: MEANS FULL THROTTLE
VALUES ARE FOR LEVEL FLIGHT WITHOUT RAM

FOR COMPLETE CRUISING DATA SEE APPENDIX 1
NOTE: TO OBTAIN U.S. GALLONS (or G.P.H.) DIVIDE FUEL IN POUNDS (or LB.P.H.) BY 6. RED FIGURES ARE PRELIMINARY SUBJECT TO REVISION AFTER FLIGHT CHECK.

TAKE-OFF CONDITIONS:
56.5" MP / 2900 RPM / RICH MIXTURE
MAX. CYL. HEAD TEMP. - 260°

CONDITIONS TO AVOID:

SPECIAL NOTES

(3) 30°C IS MINIMUM OIL TEMPERATURE FOR NORMAL TAKE-OFF.

(4) THIRTY MINUTES IS ALLOWABLE ONLY PROVIDED HEAD TEMPERATURE DOES NOT EXCEED LIMIT.

(5) DURING MILITARY POWER OPERATION, SHIFT TO HIGH BLOWER WHEN MANIFOLD PRESSURE DROPS TO 39.0" AT FULL THROTTLE IN LOW BLOWER.

(6) DURING NORMAL RATED POWER OPERATION, SHIFT TO HIGH BLOWER WHEN MANIFOLD PRESSURE DROPS TO 35.0" AT FULL THROTTLE IN LOW BLOWER.

(7) DURING MAXIMUM CRUISE POWER OPERATION, SHIFT TO HIGH BLOWER WHEN MANIFOLD PRESSURE DROPS TO 26.5" AT FULL THROTTLE IN LOW BLOWER.

ALL FUEL CONSUMPTIONS ARE BASED ON GUARANTEED SPECIFICS FOR NORMAL MIXTURE, INCREASED BY FIFTEEN PERCENT.

DATA AS OF 11 MAY 1948 BASED ON W.A.C. SPEC. NO. N836 DATED 6 SEPT 1945

WF-3-31-44-10M

AAFMC-526
H-1-22

Figure A-4 (Sheet 1 of 2 Sheets). Power Plant Chart

This chart based on the use of grade 100/
130 fuel will be provided when available.

Figure A-4 (Sheet 1 of 2 Sheets). Power Plant Chart

This chart will be provided when available.

Figure A-5. Engine Calibration Curve

RESTRICTED

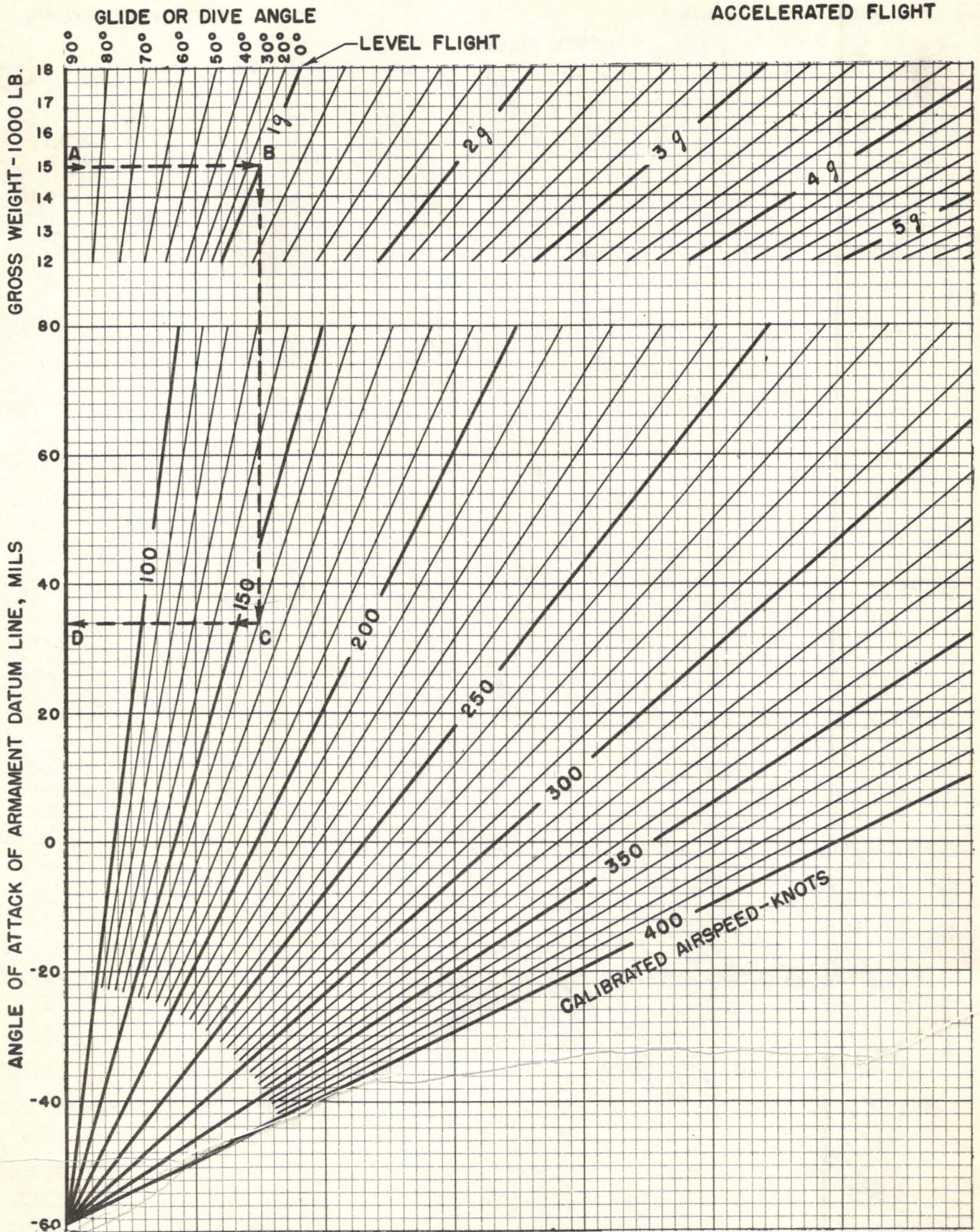

Figure A-6 (Sheet 1 of 2 Sheets). Angle of Attack Relationships (Cruising Condition)

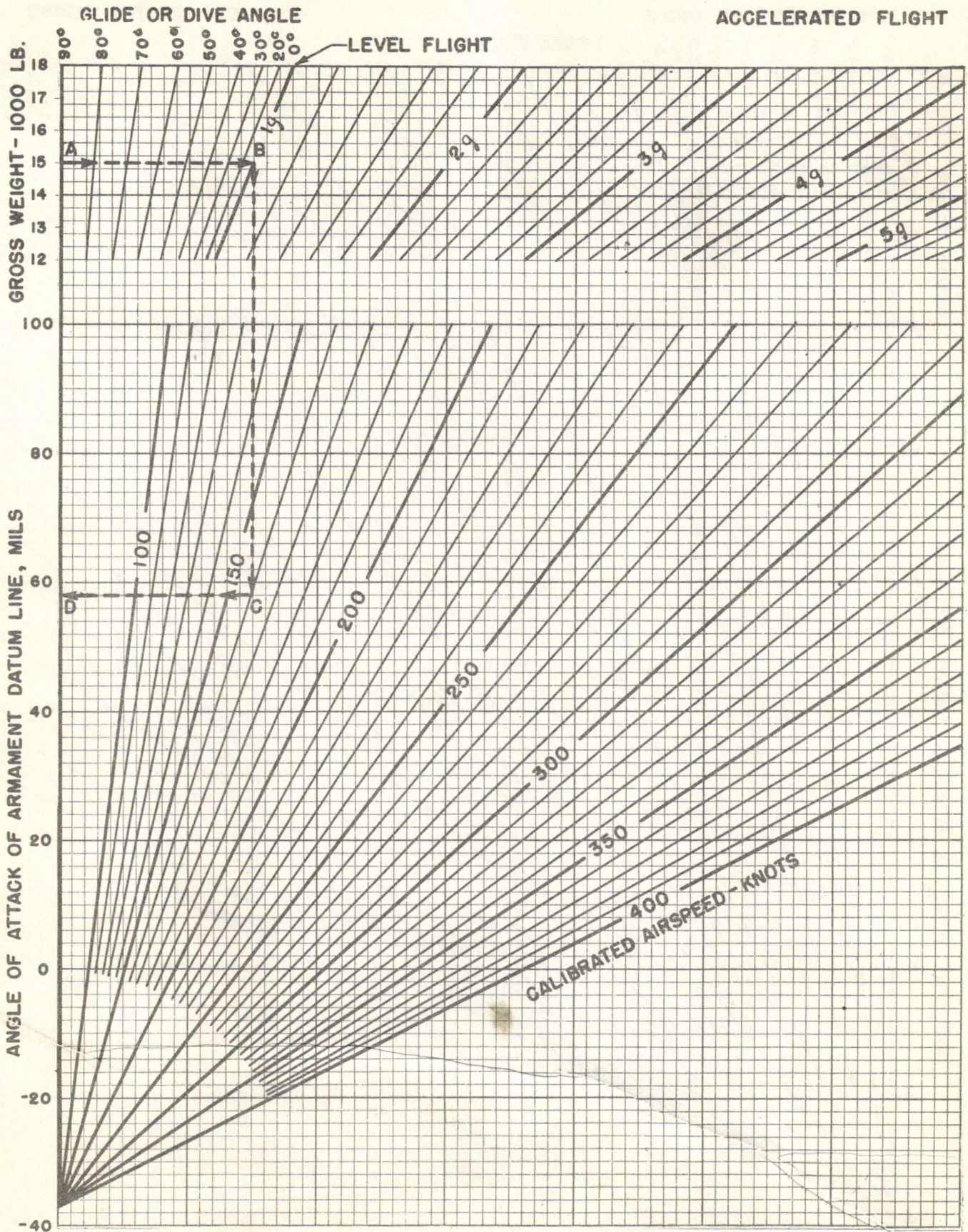

Figure A-6 (Sheet 2 of 2 Sheets). Angle of Attack Relationships (Diving Condition)

GROSS WEIGHT LB.		HEAD WIND M.P.H. KTS.		HARD SURFACE RUNWAY								SOD-TURF RUNWAY						SOFT SURFACE RUNWAY					
				AT SEA LEVEL		AT 3000 FEET		AT 6000 FEET		AT SEA LEVEL		AT 3000 FEET		AT 6000 FEET		AT SEA LEVEL		AT 3000 FEET		AT 6000 FEET			
				GROUND RUN	TO CLEAR 50' OBJ.	GROUND RUN	TO CLEAR 50' OBJ.	GROUND RUN	TO CLEAR 50' OBJ.	GROUND RUN	TO CLEAR 50' OBJ.	GROUND RUN	TO CLEAR 50' OBJ.	GROUND RUN	TO CLEAR 50' OBJ.	GROUND RUN	TO CLEAR 50' OBJ.	GROUND RUN	TO CLEAR 50' OBJ.	GROUND RUN	TO CLEAR 50' OBJ.		
18,000	0			925	1550																		
	15			630	1160																		
	25			455	920																		
	35			310	710																		
16,000	0			695	1190																		
	15			455	880																		
	25			320	680																		
	35			210	510																		
14,000	0			495	900																		
	15			310	640																		
	25			210	490																		
	35			130	360																		

NOTE: INCREASE CHART DISTANCES AS FOLLOWS: 75' F + 10%; 100' F + 20%; 125' F + 30%; 150' F + 40% (1) USE 40° FLAPS (FULL DOWN) FOR CARRIER TAKE-OFF (2) USE 25° FLAPS FOR TAKE-OFF OVER OBSTACLE
 DATA AS OF 12 MAY 1948 BASED ON: CALCULATIONS NORMAL TAKE-OFF WITH 2900 RPM, 56.5 IN. HG. & 40° DEG. FLAP IS 100% OF CHART VALUES

GROSS WEIGHT LB.	AT SEA LEVEL		AT 5000 FEET				AT 10,000 FEET				AT 15,000 FEET				AT 20,000 FEET				AT 25,000 FEET					
	BEST I. A. S.		RATE OF CLIMB F.P.M.	LBS. OF FUEL USED	BEST I. A. S.		RATE OF CLIMB F.P.M.	FROM SEA LEVEL		BEST I. A. S.		RATE OF CLIMB F.P.M.	FROM SEA LEVEL		BEST I. A. S.		RATE OF CLIMB F.P.M.	FROM SEA LEVEL		BEST I. A. S.		RATE OF CLIMB F.P.M.	FROM SEA LEVEL	
	MPH	KTS			MPH	KTS		TIME MIN.	FUEL USED LBS.	MPH	KTS		TIME MIN.	FUEL USED LBS.	MPH	KTS		TIME MIN.	FUEL USED LBS.	MPH	KTS		TIME MIN.	FUEL USED LBS.
18,000	145	2150	320	145	1980	2.5	395	145	1500	5	482	140	1040	9	585	120	890	14	740	110	500	21	875	
16,000	145	2640	320	145	2460	2	380	145	1950	4	447	140	1450	7	532	120	1310	10.5	633	110	940	15	718	
14,000	145	3340	320	145	3170	1.5	370	145	2610	3	420	140	2070	5	480	120	1900	8	520	110	1420	11	610	

POWER PLANT SETTINGS: (DETAILS ON FIG. SECTION III):
 DATA AS OF 12 MAY 1948 BASED ON: CALCULATIONS FUEL USED INCLUDES 320 LBS. FOR WARM-UP & TAKE-OFF ALLOWANCE

GROSS WEIGHT LB.	BEST IAS APPROACH		HARD DRY SURFACE								FIRM DRY SOD						WET OR SLIPPERY					
	POWER OFF		POWER ON		AT SEA LEVEL		AT 3000 FEET		AT 6000 FEET		AT SEA LEVEL		AT 3000 FEET		AT 6000 FEET		AT SEA LEVEL		AT 3000 FEET		AT 6000 FEET	
	MPH	KTS	MPH	KTS	GROUND ROLL	TO CLEAR 50' OBJ.	GROUND ROLL	TO CLEAR 50' OBJ.	GROUND ROLL	TO CLEAR 50' OBJ.	GROUND ROLL	TO CLEAR 50' OBJ.	GROUND ROLL	TO CLEAR 50' OBJ.	GROUND ROLL	TO CLEAR 50' OBJ.	GROUND ROLL	TO CLEAR 50' OBJ.	GROUND ROLL	TO CLEAR 50' OBJ.	GROUND ROLL	TO CLEAR 50' OBJ.
18,000					100	1390	3000															
16,000					90	1240	2700															
14,000					85	1080	2410															
12,000					80	930	2120															

DATA AS OF 12 MAY 1948 BASED ON: CALCULATIONS CHART VALUES ARE 100% OF NORMAL CAPABILITIES

REMARKS:
 NOTE: TO DETERMINE FUEL CONSUMPTION IN UNITED STATES GALLONS, DIVIDE FUEL IN POUNDS BY 6

LEGEND
 I. A. S. : INDICATED AIRSPEED.
 KTS. : KNOTS
 F.P.M. : FEET PER MINUTE

RESTRICTED

RESTRICTED
 AN 01-40ALA-1

Appendix I

Figure A-7. Take-Off, Climb and Landing Chart
 SCANNED BY AVIALOGS.COM

AFPM-529 8-1-48	AIRCRAFT MODEL AD-2 BOMBER CONFIGURATION	FLIGHT OPERATION INSTRUCTION CHART	EXTERNAL LOAD ITEMS ONE 2000 LB BOMB AND AN/APS-4 RADOME (SEE NOTE 3 BELOW)
	ENGINE: R-3350-26 W	CHART WEIGHT LIMITS: 16,000 TO 14,000 POUNDS	

LIMITS	RPM.	M.P. IN.HG.	BLOWER POSITION	MIXTURE POSITION	TIME LIMIT	CYL. TEMP.	TOTAL LB.P.H.	FOR DETAILS SEE POWER PLANT CHART (FIG. SECT. III)	INSTRUCTIONS FOR USING CHART: SELECT FIGURE IN FUEL COLUMN EQUAL TO OR LESS THAN AMOUNT OF FUEL TO BE USED FOR CRUISING. MOVE HORIZONTALLY TO RIGHT OR LEFT AND SELECT RANGE VALUE EQUAL TO OR GREATER THAN THE STATUTE OR NAUTICAL AIR MILES TO BE FLOWN. VERTICALLY BELOW AND OPPOSITE VALUE NEAREST DESIRED CRUISING ALTITUDE (ALT.) READ RPM, MANIFOLD PRESSURE (M.P.) AND MIXTURE SETTING REQUIRED.	NOTES: COLUMN I IS FOR EMERGENCY HIGH SPEED CRUISING ONLY. COLUMNS II, III, IV AND V GIVE PROGRESSIVE INCREASE IN RANGE AT A SACRIFICE IN SPEED. AIR MILES PER POUND (MI./LB.) (NO WIND), POUNDS PER HR. (LB.P.H.) AND TRUE AIRSPEED (T.A.S.) ARE APPROXIMATE VALUES FOR REFERENCE. RANGE VALUES ARE FOR AN AVERAGE AIRPLANE FLYING ALONE (NO WIND) TO OBTAIN U.S. GALLONS (OR G.P.H.) DIVIDE FUEL IN POUNDS (OR LB.P.H.) BY 6.
	WAR EMERG.									
	MILITARY POWER	2600 2900	50 55	HIGH LOW	NORMAL NORMAL	30 30	260 260			

COLUMN I		FUEL ⁽²⁾	COLUMN II		COLUMN III		COLUMN IV		FUEL ⁽²⁾	COLUMN V			
RANGE IN AIRMILES		LBS	RANGE IN AIRMILES		RANGE IN AIRMILES		RANGE IN AIRMILES		LBS	RANGE IN AIRMILES			
STATUTE	NAUTICAL		STATUTE	NAUTICAL	STATUTE	NAUTICAL	STATUTE	NAUTICAL		STATUTE	NAUTICAL		
SUBTRACT FUEL ALLOWANCES NOT AVAILABLE FOR CRUISING ⁽¹⁾													
		3180	INTERNAL FUEL CAPACITY PLUS TWO 150 GAL (900 LB) EXTERNAL DROP TANK								3180		
423	367	2700	665	577	900	780	1175	1020	2700	1291	1121		
376	326	2400	591	513	800	695	1043	906	2400	1150	997		
329	286	2100	517	449	700	607	915	795	2100	1005	873		
282	245	1800	444	386	600	520	784	680	1800	861	748		
235	204	1500	370	321	500	434	653	566	1500	718	623		
188	163	1200	294	255	400	347	522	453	1200	574	499		
141	122	900	222	193	300	260	392	340	900	431	374		
94	82	600	148	128	200	173	261	226	600	287	249		
47	41	300	74	64	100	87	130	113	300	143	125		

MAXIMUM CONTINUOUS										MAXIMUM AIR RANGE																				
R.P.M.	M.P. INCHES	MIX-TURE	APPROX.			PRESS ALT. FEET	R.P.M.	M.P. INCHES	MIX-TURE	APPROX.			PRESS ALT. FEET	R.P.M.	M.P. INCHES	MIX-TURE	APPROX.													
			TOT. LB.P.H.	T.A.S. MPH	KTS.					TOT. LB.P.H.	T.A.S. MPH	KTS.					TOT. LB.P.H.	T.A.S. MPH	KTS.											
						40000						40000																		
						35000						35000																		
						30000						30000																		
2600	FT	NORMAL	958	320	278	25000																								
2600	FT		1430	334	290	20000	2590	FT	NORMAL	1430	331	287	2460	32.5	NORMAL	915	305	264	2460	23	630	274	238	20000	2260	20		485	230	200
2600	44.5		1685	324	281	15000	2520	40		1345	312	271	2480	30		900	300	260	2230	25	600	260	226	15000	2000	21		433	212	184
2600	FT		1640	325	282	10000	2560	37.5		1340	310	270	2370	30.5		850	283	235	2110	26	560	243	211	10000	1870	22		382	190	165
2600	45.5		1900	318	276	5000	2380	36.5		1225	284	246	2250	31.5		798	266	231	1990	27	522	227	197	5000	1770	24		380	185	161
2600	47		1900	298	258	S.L.	2410	39		1178	273	237	2200	32.5		745	248	216	1930	28	480	209	182	S.L.	1720	25		358	171	148

- SPECIAL NOTES**
- (1) MAKE ALLOWANCE FOR WARM-UP, TAKE OFF & CLIMB (SEE FIG. A-7) PLUS ALLOWANCE FOR WIND, RESERVE AND COMBAT AS REQUIRED.
 - (2) USE HIGH BLOWER ABOVE HEAVY LINE ONLY.
 - (3) THIS CHART MAY ALSO BE USED FOR THE FOLLOWING LOADING CONDITIONS:
 - (a) ONE 1000# BOMB, AN/APS-4 RADOME, AND ONE 150 GAL. (900#) DROP TANK
 - (b) TWO 1000# BOMBS
 - (c) TWO 150 GAL (900#) DROP TANKS AND AN/APS-4 RADOME
 - (d) ONE TORPEDO AND AN/APS-4 RADOME.

EXAMPLE

AT 15,300 LB. GROSS WEIGHT WITH 1650 LB. OF FUEL (AFTER DEDUCTING TOTAL ALLOWANCES OF 630 LB.) TO FLY 500 STAT. AIRMILES AT 20,000 FT. ALTITUDE MAINTAIN 2460 RPM AND 32.5 IN. MANIFOLD PRESSURE WITH MIXTURE SET: NORMAL, AND HIGH BLOWER IN OPERATION.

LEGEND

ALT. : PRESSURE ALTITUDE
M.P. : MANIFOLD PRESSURE
LB.P.H. : POUNDS PER HOUR
TAS : TRUE AIRSPEED
KTS. : KNOTS
S.L. : SEA LEVEL

F.R. : FULL RICH
A.R. : AUTO-RICH
A.L. : AUTO-LEAN
C.L. : CRUISING LEAN
M.L. : MANUAL LEAN
F.T. : FULL THROTTLE

DATA AS OF 12 MAY 1948 BASED ON: CALCULATED AND FLIGHT TEST DATA

RED FIGURES ARE PRELIMINARY DATA, SUBJECT TO REVISION AFTER FLIGHT CHECK

Figure A-8 (Sheet 2 of 2 Sheets). Flight Operating Instruction Charts

SCANNED BY AVIALOGS.COM

RESTRICTED

AN 01-40ALA-1

RESTRICTED

Appendix I

TIME	ALTITUDE	TEMPERATURE	WIND	WEATHER	REMARKS
00:00	10000	20	000	BKN	...
00:05	10000	20	000	BKN	...
00:10	10000	20	000	BKN	...
00:15	10000	20	000	BKN	...
00:20	10000	20	000	BKN	...
00:25	10000	20	000	BKN	...
00:30	10000	20	000	BKN	...
00:35	10000	20	000	BKN	...
00:40	10000	20	000	BKN	...
00:45	10000	20	000	BKN	...
00:50	10000	20	000	BKN	...
00:55	10000	20	000	BKN	...
01:00	10000	20	000	BKN	...
01:05	10000	20	000	BKN	...
01:10	10000	20	000	BKN	...
01:15	10000	20	000	BKN	...
01:20	10000	20	000	BKN	...
01:25	10000	20	000	BKN	...
01:30	10000	20	000	BKN	...
01:35	10000	20	000	BKN	...
01:40	10000	20	000	BKN	...
01:45	10000	20	000	BKN	...
01:50	10000	20	000	BKN	...
01:55	10000	20	000	BKN	...
02:00	10000	20	000	BKN	...
02:05	10000	20	000	BKN	...
02:10	10000	20	000	BKN	...
02:15	10000	20	000	BKN	...
02:20	10000	20	000	BKN	...
02:25	10000	20	000	BKN	...
02:30	10000	20	000	BKN	...
02:35	10000	20	000	BKN	...
02:40	10000	20	000	BKN	...
02:45	10000	20	000	BKN	...
02:50	10000	20	000	BKN	...
02:55	10000	20	000	BKN	...
03:00	10000	20	000	BKN	...
03:05	10000	20	000	BKN	...
03:10	10000	20	000	BKN	...
03:15	10000	20	000	BKN	...
03:20	10000	20	000	BKN	...
03:25	10000	20	000	BKN	...
03:30	10000	20	000	BKN	...
03:35	10000	20	000	BKN	...
03:40	10000	20	000	BKN	...
03:45	10000	20	000	BKN	...
03:50	10000	20	000	BKN	...
03:55	10000	20	000	BKN	...
04:00	10000	20	000	BKN	...
04:05	10000	20	000	BKN	...
04:10	10000	20	000	BKN	...
04:15	10000	20	000	BKN	...
04:20	10000	20	000	BKN	...
04:25	10000	20	000	BKN	...
04:30	10000	20	000	BKN	...
04:35	10000	20	000	BKN	...
04:40	10000	20	000	BKN	...
04:45	10000	20	000	BKN	...
04:50	10000	20	000	BKN	...
04:55	10000	20	000	BKN	...
05:00	10000	20	000	BKN	...